



Dam Safety Review and Risk Assessment of Youbou Creek Dam

Presented To:



Dated:

March 2019

Ecora File No.:

GK-18-020-CVD

THIS PAGE IS INTENTIONALLY LEFT BLANK

Presented To:



Cowichan Valley Regional District
175 Ingram Street
Duncan, BC V9L 1N8

Prepared by:

[Signature]

 2019-03-19

Michael J. Laws, P.Eng. Date
Senior Geotechnical &
Dam Safety Engineer
michael.laws@ecora.ca

Prepared by:

[Signature] 2019-03-19
 Andrew Gain, E.I.T. Date
Junior Geotechnical/
Hydrotechnical Engineer
andrew.gain@ecora.ca

Prepared by:

[Signature] 2019-03-19
 Chelsea Evans Date

Chelsea Evans, B.E. (Hons) Civil Date
Geotechnical Consultant
chelsea.evans@ecora.ca

Prepared by:

[Signature]

 MAR 19 2019

Bram Hobuti, P.Eng. Date
Structural Engineer
bram.hobuti@ecora.ca

Reviewed by:

[Signature] 2019-03-19

Dr. Adrian Chantler, P.Eng. Date
Senior Hydrotechnical Consultant
adrian.chantler@ecora.ca

Version Control and Revision History

Version	Date	Prepared By	Reviewed By	Notes/Revisions
0	2019-03-19	MJL/AG/CE/BH	AGC	Issued for Use

Limitations of Report

This report and its contents are intended for the sole use of the Cowichan Valley Regional District, their agents and the applicable regulatory authorities. Ecora Engineering & Resource Group Ltd. (Ecora) does not accept any responsibility for the accuracy of any data, analyses, or recommendations contained or referenced in the report when the report is used or relied upon by any Party other than the Cowichan Valley Regional District, their agents, the applicable regulatory authorities or for any Project other than that described in this report. Any such unauthorized use of this report is at the sole risk of the user.

Where Ecora submits both electronic file and hard copy versions of reports, drawings and other project-related documents, only the signed and/or sealed versions shall be considered final and legally binding. The original signed and/or sealed version archived by Ecora shall be deemed to be the original for the Project. Both electronic file and hard copy versions of Ecora's deliverables shall not, under any circumstances, no matter who owns or uses them, be altered by any party except Ecora.

Ecora's General Conditions are provided in Appendix I of this report.

Executive Summary

The Cowichan Valley Regional District (CVRD) engaged Ecora Engineering & Resource Group Ltd. (Ecora) to undertake a comprehensive Dam Safety Review (DSR) and risk assessment of the Youbou Creek Dam located near the community of Youbou, BC on the northern shore of Cowichan Lake.

Table i Summary of Key Dam Attributes

Youbou Creek Dam	
Provincial Dam File Number:	D730170-00
Stream Name:	Youbou Creek
Current Consequences Classification:	Significant
Dam Type:	Concrete Gravity
Location:	Latitude: 48°52'42" N Longitude: 124°12'52" W
Height:	9 m
Length:	18.3 m
Crest Width:	0.46 m
Spillway Capacity:	2.7 m ³ /s
Live Storage:	460 m ³
Potential Storage:	1,770 m ³ /s (without sediment)
Drainage Area:	209 ha
Peak of Inflow Design Flood (IDF):	34.2 m ³ /s – 42.3 m ³ /s (Significant, 100-y to 1000-y flood)
Peak Outflow During IDF:	34.2 m ³ /s – 42.3 m ³ /s (Significant, 100-y to 1000-y flood)

The DSR was undertaken in general accordance with the requirements of the BC Water Sustainability Act including all amendments up to BC Reg. 301/2016 (December 7, 2016), the BC Dam Safety Regulation BC Reg. 40/2016 (February 29, 2016), The Association of Professional Engineers and Geoscientists of BC (APEGBC) Professional Practice Guidelines – Legislated Dam Safety Reviews in BC V3.0 (October 2016), and the Canadian Dam Association (CDA) Dam Safety Guidelines (DSG) 2007 (2013 Edition).

The scope of the DSR included the following tasks:

- Background review;
- Site reconnaissance;
- Review of consequences classification;
- Dam assessment, including wall stability and seepage;
- Hydrotechnical analysis including dam break analysis, flood routing and hydraulics;
- Review of any existing Operation, Maintenance & Surveillance Manual, Dam Emergency Plans (Emergency Response Plan and/or Emergency Preparedness Plan), and/or public safety management strategies;
- Risk assessment as per the NDMP framework;
- Assessment of compliance with CDA design criteria; and,
- Development of conclusions and recommendations.

Key outcomes from the engineering analyses are summarized in Table ii below.

Table ii Summary of Results from Engineering Analyses

Does the dam meet CDA design criteria?	Yes/No	Comments
Is the current consequences classification appropriate for this dam in accordance with the BC Dam Safety Regulation BC Reg. 40/2016?	Yes	See Section 6
Does the strength and/or characteristics of the dam foundation materials provide sufficient resistance to liquefaction or softening during seismic (cyclic) loading due to application of the EDGM?	Yes	See Section 8.6
Does the dam meet minimum CDA sliding stability criteria for all loading conditions?	No	See Section 8.4
Does the position of the force resultant meet CDA minimum criteria for all loading conditions?	No	See Section 8.4
Are tensile stresses (normal, perpendicular) within the limits of CDA acceptance criteria?	No	See Section 8.4
Does the dam meet CDA minimum static global stability criteria?	No	See Section 8.4
Does the dam meet CDA minimum pseudo-static global stability criteria?	No	See Section 8.4
Does the dam meet CDA minimum post-earthquake global stability criteria?	No	See Section 8.4
Do the characteristics of the dam foundation materials provide sufficient resistance to and/or control of seepage to prevent internal erosion?	Yes	See Section 8.7
Does the spillway have sufficient capacity to safely pass the inflow design flood (IDF)?	No	See Section 9.5
Does the dam meet CDA freeboard requirements including the effects of wind and wave action?	No	See Section 9.5

Based on the results of the site reconnaissance, analyses and assessment of the dam, a number of observations, conclusions and recommendations were developed as summarized in Table iii below. Priorities (Low, Medium, High or Very High) are given in parentheses. Low, Medium, High and Very High priority recommendations should be addressed within 5, 3, 1 and 0.5 year(s) respectively.

Table iii Dam Safety Review of Youbou Creek Dam — Observations, Conclusions and Recommendations

Task	Observations & Conclusions	Recommendations
Background Review	<ul style="list-style-type: none"> Limited background information is available for this dam and does not include record drawings for the dam structure. The dam was constructed at some point prior to 1959. No obvious signs of historical or current slope instability of the reservoir side slopes were observed in the review of available photographs. 	<ul style="list-style-type: none"> As no record drawings are available for the dam structure, a detailed topographical survey of the dam embankment, abutments, outlet and spillway channel should be commissioned to verify existing dam geometry, confirm critical dam elevations and to assist in any future engineering assessments (High).
Site Reconnaissance	<ul style="list-style-type: none"> The reservoir and sedimentation basin were both filled with sediment at the time of the site reconnaissance. Vegetation is currently growing out of the face of the dam. Concrete is showing significant wear on the downstream face. 	<ul style="list-style-type: none"> If CVRD would like to continue to use the dam for drinking water purposes it is recommended that the sediment be removed from the reservoir to restore the available storage capacity (Low).
Consequences Classification	<ul style="list-style-type: none"> The dam breach inundation mapping indicates that a total area of approximately 1.05 km² would be flooded in the event of a dam breach during a 100-year event, potentially impacting Youbou Road and properties downstream. Dam breach analysis and inundation mapping results confirmed that the consequences classification for Youbou Creek Dam should be maintained as "Significant". The CDA guidelines recommend an Inflow Design Flood (IDF) for a "Significant" consequences dam to be between the 100-year and the 1,000-year event. 	<ul style="list-style-type: none"> There are no recommendations in this area of the review.
Failure Mode Assessment	<ul style="list-style-type: none"> The plausible failure modes of the dam are; overtopping as the spillway may become blocked with debris, deformation & deterioration due to age and sliding/overturning failure from the design flood or seismic forces. 	<ul style="list-style-type: none"> There are no recommendations in this area of the review.
Geotechnical Assessment	<ul style="list-style-type: none"> Results of the stability assessment indicate that the dam does not meet CDA structural stability criteria for normal, flood and post-earthquake loading conditions. The earthquake load combination meets or exceeds minimum CDA criteria. The allowable bearing capacity of the foundation is adequate to resist the maximum compressive stress for normal, flood, earthquake and post-earthquake loading conditions. The dam foundation is considered to have a very low susceptibility to liquefaction and post seismic deformation when subject to strong ground motion. The dam foundation is considered to have an extremely low susceptibility to piping failure. The calculated Melton Ratio for Youbou Creek was determined to be 0.6 which indicate that the creek may be susceptible to the formation of debris flows, debris floods and floods. 	<ul style="list-style-type: none"> CVRD should commission a design study to address the major deficiencies in the Youbou Creek Dam, namely to increase its resistance to sliding and overturning to meet CDA stability criteria or alternatively decommission the dam. It is envisioned this would result in a recommendation to remediate the existing dam that would likely include the design of a reinforced concrete toe buttress to increase the stability of the gravity wall (Very High). If it is chosen to remediate the existing dam, it is recommended that areas of concrete deterioration particularly in vicinity of cold joints are addressed. Remediation or decommissioning of the existing dam should consider the potential impacts of debris floods and debris flows as the existing sediment basin and reservoir provides some mitigation of this hazard to the community of Youbou.
Hydrotechnical Assessment	<ul style="list-style-type: none"> The peak inflow to Youbou Creek Dam during the IDF associated with the recommended "Significant" consequences classification is between 34.2 m³/s (100-year) and the 42.3 m³/s (1,000-year). Because of the absence of significant storage, peak outflows are the same. The spillway does not have adequate capacity to pass the IDF associated with the "Significant" consequences classification. The capacity of the spillway is estimated to be 2.7 m³/s. The flood routing exercise determined that during the IDF event the dam crest will be overtopped. Given that Youbou Creek Dam is a concrete gravity dam, it should be able to resist overtopping without serious damage and given the wear pattern on the dam, it has likely overtopped in the past. 	<ul style="list-style-type: none"> Extra spillway capacity should be added to the dam to allow for passage of the IDF event or the dam should be strengthened so that the dam would be able to resist forces generated by an overtopping event during the IDF (High).
Dam Safety Management	<ul style="list-style-type: none"> An Operations, Maintenance and Surveillance Manual and a Dam Emergency Plan need to be prepared for Youbou Creek. 	<ul style="list-style-type: none"> An Operation, Maintenance and Surveillance Manual and a Dam Emergency Plan need to be prepared for Youbou Creek Dam (High). The dam should either be decommissioned or rehabilitated to meet design loading criteria (High).
Risk Assessment	<ul style="list-style-type: none"> The dam does not meet current CDA requirements in terms of sliding and overturning and thus failure of the dam may occur due to conditions expected over a 30-year period corresponding to an NDMP rating of 1. A preliminary estimate of reconstruction costs as a result of a dam breach is between \$300,000 and \$3 million based on the scope of the infrastructure impacted. 	<ul style="list-style-type: none"> Should the CVRD wish to proceed with a NDMP funding application to remediate or replace Youbou Creek Dam they should undertake a more detailed cost estimate of infrastructure that would be impacted in the event of a dam breach (High).

THIS PAGE IS INTENTIONALLY LEFT BLANK

Table of Contents

- 1. Introduction 1
 - 1.1 General1
 - 1.2 Dam Description and Access1
 - 1.3 Operation, Maintenance and Surveillance2

- 2. Scope of Work..... 2
 - 2.1 Comprehensive Dam Safety Review.....2
 - 2.2 NDMP Risk Assessment3

- 3. Background Review 3
 - 3.1 Sources of Information3
 - 3.2 Design, Construction and Modification4
 - 3.3 Historical Aerial Photographs4
 - 3.4 Geological Setting5
 - 3.5 Seismicity.....5
 - 3.6 Existing Drawings6
 - 3.7 Instrumentation6
 - 3.8 Previous Dam Safety Reviews6

- 4. Site Reconnaissance..... 6
 - 4.1 General6
 - 4.2 Visual Inspection7
 - 4.3 Structural Observations7
 - 4.4 Staff Interviews8

- 5. Dam Break Analysis 8

- 6. Consequences Classification 10
 - 6.1 General 10
 - 6.2 Consequences Classification Review 14
 - 6.2.1 General..... 14
 - 6.2.2 Loss of Life14
 - 6.2.3 Environmental and Cultural Losses 14
 - 6.2.4 Infrastructure and Economic Losses 14

6.3	Conclusions	15
7.	Failure Modes Assessment	15
8.	Geotechnical & Structural Assessment	16
8.1	General.....	16
8.2	Material Parameters Estimation	17
8.2.1	Concrete Gravity Wall.....	17
8.2.2	Geotechnical Parameters.....	17
8.3	Seepage Through Foundation.....	17
8.4	Structural Stability Review.....	18
8.4.1	Acceptance Criteria	18
8.4.2	Methodology.....	19
8.4.3	Load Combinations	19
8.4.4	Results	20
8.5	Gravity Wall Foundation Review	20
8.6	Liquefaction and Post-Earthquake Deformation.....	20
8.7	Internal Erosion (Piping).....	20
8.7.1	Internal Erosion Mechanisms	20
8.7.2	Piping Potential	21
8.8	Debris Flow, Debris Flood and Flood Hazard Assessment.....	21
9.	Hydrotechnical Assessment	22
9.1	Watershed	22
9.2	Climatic and Snow Course Data.....	23
9.3	Hydrometric Data.....	24
9.4	Determination of Inflow Design Flood	24
9.4.1	General.....	24
9.4.2	Determination of the 1,000-Year Flood	25
9.4.3	Inflow Design Flood.....	26
9.5	Flood Routing and Freeboard Determination	27
9.5.1	Volume-Elevation Relationship.....	27
9.5.2	Rating Curve	27
9.5.3	Flood Routing Results.....	27
9.5.4	Wind and Wave Considerations	28
9.5.5	Freeboard Assessment	28
10.	Dam Safety Management System.....	28

10.1	General	28
10.2	Operations, Maintenance and Surveillance Manual.....	29
10.3	Dam Emergency Plan.....	29
10.4	Public Safety Management.....	29
10.5	Dam Safety Expectations Assessment	29
10.5.1	General	29
10.5.2	Dam Safety Analysis	30
10.5.3	Operations, Maintenance and Surveillance	30
10.5.4	Emergency Preparedness.....	30
10.5.5	Dam Safety Review.....	31
10.5.6	Dam Safety Management.....	31
11.	Risk Assessment.....	31
11.1	General	31
11.2	Risk Assessment Information	31
11.3	Risk Assessment Summary.....	32
11.4	Confidence Levels	33
12.	Observations and Conclusions.....	33
12.1	Background Review.....	33
12.2	Site Reconnaissance.....	33
12.3	Consequences Classification Review	33
12.4	Failure Mode Assessment.....	34
12.5	Geotechnical & Structural Assessment	34
12.6	Hydrotechnical Assessment	34
12.7	Dam Safety Management.....	34
12.8	Risk Assessment	35
13.	Recommendations	35
13.1	Background Review.....	35
13.2	Site Reconnaissance.....	35
13.3	Consequences Classification Review	35
13.4	Failure Mode Assessment.....	35
13.5	Geotechnical and Structural Assessment	35
13.6	Hydrotechnical Assessment	36
13.7	Dam Safety Management.....	36
13.8	Risk Assessment	36

14. Dam Safety Review Assurance Statement 36

References..... 37

List of Tables in Text

Table 1.3 Summary of Water Licence for Youbou Creek2

Table 2.2 Likelihood Rating Scale3

Table 3.3 Summary of Reviewed Aerial Photographs of the Youbou Creek Dam Area4

Table 3.5.a Site Class C Design PGA and Sa for Youbou Creek Dam, Youbou, BC5

Table 3.5.b Extrapolated Site Class C Design PGA and Sa for Youbou Creek Dam, Youbou, BC6

Table 3.5.c Design Earthquake Magnitudes for Youbou Creek Dam, Youbou, BC6

Table 5.0.a Summary of Dam Breach Parameters9

Table 5.0.b Suggested Limiting Froude (Fr) Numbers¹9

Table 5.0.c Definition of Water Flood Intensity10

Table 6.1 Acceptance Criteria for Concrete Gravity Dams12

Table 6.2 Property Loss Criteria based on Consequences Classification15

Table 7.0 Summary of Causes of Static Concrete Dam Failures16

Table 8.2 Summary of Geotechnical Parameters Used in the Dam Assessment17

Table 8.3 Estimated Rate of Toe Seepage for the Youbou Creek Dam18

Table 8.4.a Acceptance Criteria for Concrete Gravity Dams18

Table 8.4.b Factors of Safety for Stability of the Youbou Creek Dam20

Table 8.8 Typical Hazard for Melton Ratios22

Table 9.2.a Regional Climate Stations23

Table 9.2.b Rainfall Intensity Frequency Data at Regional Climate Stations23

Table 9.2.c Regional Snow Pillow Station24

Table 9.2.d Average Snowpack Data for Jump Creek Snow Pillow24

Table 9.3 Regional Hydrometric Stations24

Table 9.4.a 1000-Year 24-Hour Rainfall25

Table 9.4.b Regional Analysis Peak Flood Estimates26

Table 9.5 Results of Flood Routing28

Appendix Sections

Figures

Figure 1.2a Site Plan

Figure 1.2b General Site Location & Access Routes

Figure 3.4 Bedrock Geology

Figure 4.1 Estimated Dimensions of Youbou Creek Dam

Figure 5.0a Extent of Inundation & Maximum Flow Depth

Figure 5.0b	Time (Hrs) for 0.6 m Flow Depth
Figure 5.0c	Flood Hazard Rating
Figure 8.3	Steady State Seepage Analysis: Reservoir Level at Spillway Elevation
Figure 8.8	Melton Ratio of Youbou Creek
Figure 9.1	Youbou Creek Watershed
Figure 9.2	Climate and Automated Snow Pillow Stations
Figure 9.3	Hydrometric Stations
Figure 9.4	Inflow Design Flood Hydrographs
Figure 9.5a	Youbou Creek Dam Area Elevation Storage Curves
Figure 9.5b	Youbou Creek Dam Spillway Rating Curve
Figure 9.5c	Youbou Creek Dam Flood Routing Hydrographs
Figure 9.5d	Youbou Creek Dam Reservoir Flood Levels
Figure 10.1	Dam Safety Management System

Photographs

Photo 1	Upstream stilling basin and channel leading to culvert.
Photo 2	Reservoir as seen from the upstream side of the dam.
Photo 3	Culvert discharging into reservoir upstream of the dam.
Photo 4	Right upstream access to the dam crest.
Photo 5	Dam crest as viewed from right side of the dam.
Photo 6	Upstream face of the dam above the waterline.
Photo 7	Corroded bent guardrail on the dam crest.
Photo 8	Weathering of concrete on the left side of the spillway at the stoplog insert.
Photo 9	Concrete deterioration at edge of spillway.
Photo 10	Concrete deterioration above and below water line.
Photo 11	Backside of cold joint as viewed from within the reservoir.
Photo 12	Downstream face of the dam as viewed from above at the right abutment.
Photo 13	Downstream face of the dam as viewed from below looking towards right abutment.
Photo 14	Horizontal cracking and erosion on downstream dam face approximately 1 m below the crest.
Photo 15	Vegetation growing on the dam face to the right of the spillway.
Photo 16	Water flowing over spillway as viewed from below.
Photo 17	Downstream face of the dam as viewed from downstream.
Photo 18	Horizontal groove on the left downstream face approximately 1.7 m below the crest.
Photo 19	Weathering on the downstream face noted throughout the crest and front face.
Photo 20	Downstream face as viewed from the left of the spillway.
Photo 21	Low level outlet on the right side of the dam.
Photo 22	Low level outlet pipe and water intake line at left side of the dam.
Photo 23	Low level outlet and water intake pipes viewed from dam crest.
Photo 24	Outlet channel as viewed from the dam crest.

Appendices

Appendix A	Background Information Reviewed
Appendix B	Existing Dam Drawings
Appendix C	Dam Inspection Notes
Appendix D	Hazard and Failure Modes Analysis
Appendix E	Dam Stability and Foundation Calculations
Appendix F	Check Sheets for Dam Safety Expectations, Deficiencies and Priorities
Appendix G	NDMP Risk Assessment Information Template
Appendix H	Dam Safety Assurance Statement
Appendix I	Statement of General Conditions – Geotechnical

Acronyms and Abbreviations

AEP	Annual Exceedance Probability
ALARP	As Low As Reasonably Practicable
AMSL	Above Mean Sea Level
APEGBC	Association of Professional Engineers and Geoscientists of British Columbia
BC	British Columbia
BC MoE	British Columbia Ministry of Environment
CDA	Canadian Dam Association
CSP	Corrugated Steel Pipe
CSR	Cyclic Stress Ratio
CSRS	Canadian Spatial Reference System
CVRD	Cowichan Valley Regional District
DBE	Dam Breach Elevation
DDSP	Directive for Dam Safety Program
DEP	Dam Emergency Plan
DSG	Dam Safety Guidelines, Canadian Dam Association 2007
DSR	Dam Safety Review
EDGM	Earthquake Design Ground Motion
EPP	Emergency Preparedness Plan
ERP	Emergency Response Plan
FEMA	Federal Emergency Management Agency
FoS	Factor of Safety
FSR	Forestry Service Road
GPR	Ground Penetrating Radar
GPS	Global Positioning System
GSC	Geological Survey of Canada
HEC-HMS	Hydrologic Engineering Center - Hydrologic Modeling System
ICOLD	International Congress on Large Dams
IDF	Inflow Design Flood
LOL	Loss of Life
MFLNRORD	Ministry of Forests, Lands, Natural Resource Operations & Rural Development

MSC	Meteorological Service of Canada
NAD	North American Datum
NBCC	National Building Code of Canada
NDMP	National Disaster Mitigation Program
OMS	Operations, Maintenance and Surveillance
PAR	Population at Risk
PGA	Peak Ground Acceleration
PMF	Probable Maximum Flood
PMP	Probable Maximum Precipitation
PPP	Precise Point Positioning
PSP	Public Safety Plan
RAIT	Risk Assessment Information Template
RFP	Request for Proposal
Sa(T)	Spectral Accelerations
SCS	US Soil Conservation Service
SMPDBK	Simplified Dam-Break
TRIM	Terrain Resource Information Management
UBC	University of British Columbia
US	United States
USBR	United States Bureau of Reclamation
UTM	Universal Transverse Mercator
USGS	United States Geological Survey

1. Introduction

1.1 General

The Cowichan Valley Regional District (CVRD) engaged Ecora Engineering & Resource Group Ltd. (Ecora) to undertake a comprehensive Dam Safety Review (DSR) and risk assessment of the Youbou Creek Dam located near the community of Youbou, BC on the northern shore of Cowichan Lake.

The dam functions as part of the CVRD managed township of Youbou water distribution system.

This report presents the technical findings of the Youbou Creek Dam DSR and it is understood that this is the first comprehensive DSR of this facility.

A DSR is considered to be a “snapshot in time” and the observations, conclusions, and recommendations provided in this report are deemed to be valid until the next scheduled DSR which should be conducted in 10 years (2028) for the Youbou Creek Dam as per the Canadian Dam Association (CDA) DSR Guidelines 2007 (2013 Edition). However, if conditions (e.g. loading, reservoir level, etc.) change, the results of this DSR may no longer be considered valid and/or current, and a reassessment may be required.

Youbou Creek Dam is catalogued in the BC Ministry of Forests, Lands, Natural Resource Operations & Rural Development (MFLNRORD) Dam Safety Section, Dam File No. D730170-00. The BC MFLNRORD has currently assigned the dam a consequences classification rating of “Significant” in terms of the BC Dam Safety Regulation (BC Reg. 40/2016), and the Canadian Dam Association (CDA) DSR Guidelines 2007 (2013 Edition).

The DSR was undertaken in general accordance with the requirements of the British Columbia Water Sustainability Act including all amendments up to BC Reg. 301/2016 (December 7, 2016), the BC Dam Safety Regulation BC Reg. 40/2016 (February 29, 2016), the Association of Professional Engineers and Geoscientists of BC (APEGBC) Professional Practice Guidelines – Legislated Dam Safety Reviews in BC V3.0 (October 2016), and the Canadian Dam Association (CDA) Dam Safety Guidelines (DSG) 2007 (2013 Edition).

The objective of the British Columbia Dam Safety Regulation (BC Reg. 40/2016) is to mitigate loss of life and damage to property and the environment from a dam breach. This Regulation requires dam owners to:

- Operate the dam in a safe manner in accordance with any terms and conditions;
- Inspect their dams;
- Undertake proper maintenance;
- Report incidents and take remedial action; and,
- Undertake periodic Dam Safety Reviews.

The risk assessment of the Youbou Creek Dam was undertaken in general accordance with the National Disaster Mitigation Program (NDMP) framework.

1.2 Dam Description and Access

Youbou Creek Dam is a concrete gravity dam situated on Youbou Creek approximately 0.5 km north of Cowichan Lake, at Map Grid (NAD 83) co-ordinates E410956, N5414653 (Zone 10). The dam is oriented east to west and is

situated in a north to south trending ravine. The dam impounds approximately 1770 m³ of water at the spillway level, with a watershed area of approximately 2.09 km² upstream of the dam.

According to the Ministry of Forests, Lands, Natural Resource Operations and Rural Development (MFLNRORD) dam database, Youbou Creek Dam has a height of 9 m with a crest length of 18.3 m. The spillway for the facility is an overflow weir located in the centre of the structure. Measurements taken at the time of inspection estimated the spillway to be 0.76 m in height with a length of 2.38 m. The top width of the structure is estimated as 0.46 m. The downstream face of the structure is estimated to be sloped at 20° to the vertical.

Stored water can be discharged via three low level outlet pipes. Two discharge directly to Youbou Creek at the downstream toe of the dam on either side of the spillway and a third, that acts as an intake for the town's water supply, is located on the left side (looking downstream) of the dam.

A sedimentation basin is located upstream, which feeds into the reservoir through twin Corrugated Steel Pipe (CSP) culverts estimated to be 1.2 m and 1.1 m in diameter located above the reservoir. Three culverts are located directly downstream of the dam under the access road and are estimated to be 1.1 m in diameter.

Public access to the dam is provided from Youbou, BC, via Youbou Road with directions as follows. Travel westbound along Youbou Road. Turn right onto Hemlock Street. Follow pavement around corner to Community Lane. Turn right onto the second gravel road approximately 75 m from corner. Continue for 200 m to dam. The site location is presented in Figure 1.2a and the access route is shown in Figure 1.2b.

1.3 Operation, Maintenance and Surveillance

Operations at Youbou Creek Dam are regulated under the conditional water licence summarized in Table 1.3 below.

Table 1.3 Summary of Water Licence for Youbou Creek

Licence Type	Licence Number	Purpose	Quantity (m ³ /year)	Licence Holder
Conditional	C037415	Waterworks: Local Provider	63054.268	CVRD

Copies of individual water licenses can be found at http://a100.gov.bc.ca/pub/wtrwhse/water_licences.input.

It is understood that the day to day operation and maintenance of the Youbou Creek Dam is overseen by the CVRD.

From discussions with the CVRD, it is understood that surveillance (inspection) of the dam is generally undertaken weekly, weather permitting, however it is not documented. Formal annual inspections are carried out using the MFLNRORD dam site surveillance template.

2. Scope of Work

2.1 Comprehensive Dam Safety Review

Ecora's scope of work for the DSR was developed in accordance with the requirements of the CDA Dam Safety Guidelines 2007 (2013 Edition). In summary, the study included the following tasks:

- Background review;
- Site reconnaissance;
- Review of consequences classification;

- Geotechnical assessment including seepage analyses, piping potential and considerations for liquefaction and post-earthquake deformation;
- Structural stability assessment including calculation of the position of the resultant force, normal stresses, and calculated sliding factors;
- Hydrotechnical analysis including hydrological analysis, dam break analysis, flood routing and hydraulics;
- Review of any existing Operation, Maintenance & Surveillance Manual;
- Review of any existing Dam Emergency Plans (Emergency Response Plan and/or Emergency Preparedness Plan);
- Review of any public safety management strategies;
- Risk assessment as per the NDMP framework;
- Assessment of compliance with CDA design criteria; and,
- Development of conclusions and recommendations.

The results of each task are detailed in the following sections.

2.2 NDMP Risk Assessment

The NDMP Risk Assessment Information Template (RAIT) provides a likelihood rating scale for a specific risk event and the likelihood that this event will occur based on conditions expected over a certain timeframe (Table 2.2). As the consequences of a dam failure (break) are the same, the event for this assessment is defined as any embankment overtopping, internal erosion, slope instability and/or earthquake induced condition(s) that cause failure of Youbou Creek Dam. The NDMP RAIT is discussed in more detail in Section 11.

Table 2.2 Likelihood Rating Scale

Likelihood Rating	Definition
5	The event is expected and may be triggered by conditions expected over a 30-year period.
4	The event is expected and may be triggered by conditions expected over a 30 – 50-year period
3	The event is expected and may be triggered by conditions expected over a 50 – 500-year period
2	The event is expected and may be triggered by conditions expected over a 500 – 5,000-year period
1	The event is possible and may be triggered by conditions exceeding a period of 5,000 years

3. Background Review

3.1 Sources of Information

The following sources of background information were reviewed during the DSR:

- Historic aerial photographs;

- Readily available published sources of geological data;
- Existing dam and reservoir drawings;
- Discussions with CVRD staff familiar with the site; and,
- MFLNRORD Dam Safety Branch files.

A detailed list of the various documents reviewed from these sources is provided in Appendix A.

3.2 Design, Construction and Modification

There is limited information available with respect to the design and construction of Youbou Creek Dam, however it is known that the dam was originally constructed by a nearby sawmill that has since closed. The background information available at the time of the dam safety review on the construction and history of the dam is listed in Appendix A and is predominantly related to the reservoir rather than the concrete gravity dam structure. It isn't clear in what year the dam was constructed.

A review of documentation for the Youbou Creek Dam indicates that there is only one existing drawing of the dam, namely a sketch dated March 1991 for a work order of proposed repairs of the dam (W.O. #4125). This sketch is presented in Appendix B. The listed items for the work order included:

- Make sure spillway boards are usable when required;
- Repair steps;
- Replace boards and blind flange around pipework downstream of dam to the townsite;
- Dredge stilling basin and replace small dam;
- Repair and rehing 4" pipe between stilling basin and dam; and,
- Dredge dam basin.

There is no documentation available for the completion of this work order.

3.3 Historical Aerial Photographs

A review was conducted of available historical aerial photographs of the Youbou Creek Dam area held by the Geography Department of the University of British Columbia (UBC) as summarized in Table 3.3 below.

Table 3.3 Summary of Reviewed Aerial Photographs of the Youbou Creek Dam Area

Year	Aerial Photo No.	Type
1946	BC247:12	Black and White
1949	BC816:112	Black and White
1959	BC5006:117-116	Black and White
1962	BC5044:79-78	Black and White
1968	BC7109:121-120	Black and White
1972	BC7410:103-102	Black and White
1979	30BCC205:37-36	Colour
1984	30BC84026:235-236	Black and White

Year	Aerial Photo No.	Type
1990	30BCC90013:17-16	Black and White
2007	ME07464C:46-45	Colour

The review of the available historical aerial photographs included the historical condition of the dam, reservoir side slopes and catchment noting the following:

- The dam was obscured by foliage in most photographs reviewed. The earliest photo which the dam was clearly visible was 1959, however an access road that leads towards the dam appears to exist as early as 1946;
- Large areas to the east and west of the dam were deforested prior to 1946, and remained deforested in 1949, 1959 and 1962;
- Forest service roads (FSR) north of Youbou Creek Dam were constructed between the 1968 and 1972 historical aerial photographs, with a large area to the north in the upper reaches of the catchment deforested; and
- No obvious signs of instability or erosion of the dam watershed were observed in the photos.

3.4 Geological Setting

The Geological Survey of Canada (GSC) 1:50,000,000 scale map “Geological Map of Canada” indicates that the site is underlain by thickly bedded tuffite and lithic tuffite, breccia, tuff, feldspar and quartz-feldspar, crystal tuff, lapilli tuff, rhyolite, dacite, laminated tuff, jasper, chert, hematite-chert iron formation. The bedrock geology for the site is presented on Figure 3.4.

3.5 Seismicity

The GSC has developed a new probabilistic (5th Generation) seismic hazard model (Halchuk, Adams and Allen, 2015) that forms the basis of the seismic design provisions of the 2015 National Building Code of Canada (NBCC, 2015).

Based on the surficial geology of the area, which indicates shallow bedrock, the site classification for seismic response for the Youbou Creek Dam is considered to be Site Class C (very dense soil and soft rock). Peak Ground Accelerations (PGA) and Spectral Accelerations (Sa(T)) for a reference “Site Class C” (very dense soil and soft rock) can be obtained from Earthquakes Canada for various return periods, with the reference values for the Youbou Creek Dam summarized in Table 3.5.a.

Table 3.5.a Site Class C Design PGA and Sa for Youbou Creek Dam, Youbou, BC

Annual Exceedance Probability (AEP)	PGA (g)	Sa(0.2)	Sa(0.5)	Sa(1.0)	Sa(2.0)
1/100 year	0.103	0.241	0.198	0.095	0.050
1/475 year	0.264	0.604	0.533	0.281	0.157
1/1,000 year	0.375	0.847	0.777	0.438	0.256
1/2,475 year	0.535	1.196	1.126	0.683	0.415

For seismic hazards with very low probabilities (i.e. return periods greater than 2,475 years) the GSC recommends plotting the annual probability versus acceleration of the 1/475 year and 1/2,475 year values on a log-log scale and extrapolating the line to the required return period. Extrapolated site “Class C” PGA and Sa(T) reference values for the Youbou Creek Dam are summarized in Table 3.5.b.

Table 3.5.b Extrapolated Site Class C Design PGA and Sa for Youbou Creek Dam, Youbou, BC

Annual Exceedance Probability (AEP)	PGA (g)	Sa(0.2)	Sa(0.5)	Sa(1.0)	Sa(2.0)
1/5,000 year	0.854	1.208	1.188	1.000	0.813
1/10,000 year	0.995	1.333	1.333	1.167	0.958

With respect to selection of earthquake design magnitudes the CDA Technical Bulletin, Seismic Hazard Considerations for Dam Safety recommends utilising the greatest of the mean magnitude, modal magnitude or the 84th percentile of the total magnitude contributions when considering multiple seismogenic probabilistic seismic hazards.

The relative contribution of the earthquake sources to the seismic hazard in terms of distance and magnitude can be obtained by deaggregation of the seismic hazard result. The deaggregation data for the NBCC 2015 design model has been obtained from Earthquakes Canada, which provides the mean and modal magnitude of the seismic hazard for the Youbou Creek Dam for the 1/2,475 year event as summarized in Table 3.5.c.

Table 3.5.c Design Earthquake Magnitudes for Youbou Creek Dam, Youbou, BC

Magnitude Contributions	PGA	Sa(0.2)	Sa(0.5)	Sa(1.0)	Sa(2.0)
Mean	7.910	7.810	8.080	8.470	8.640
Modal	8.950	8.950	8.950	8.950	8.950
84 th Percentile	9.050	9.000	9.050	9.100	9.100

3.6 Existing Drawings

As discussed in Section 3.2, a review of existing documentation for the Youbou Creek Dam indicates that there is only one existing drawing of the dam, namely a sketch dated March 1991 for a work order of proposed repairs of the dam (W.O. #4125). This sketch is presented on Appendix B.

3.7 Instrumentation

There is no instrumentation installed in Youbou Creek Dam.

3.8 Previous Dam Safety Reviews

It is understood that this DSR is the first for this facility and as such no previous DSR is available for review.

4. Site Reconnaissance

4.1 General

Ecora conducted a site reconnaissance of the Youbou Creek Dam on two occasions, as part of the Request for Proposal (RFP) on January 17, 2018 and as part of a scheduled site inspection on March 28, 2018. Ecora's site representatives in March were Michael J. Laws, P.Eng, Caleb Pomeroy, P.Eng., Dr. Adrian Chantler, P.Eng. and Bram Hobuti, P.Eng.

The site reconnaissance comprised three components, namely:

- A visual inspection of the exposed section of the dam, underwater pole camera inspection of the submerged upstream slope of the dam, a simple survey of the height of sediment behind the dam and tour of some of the area in the vicinity of Youbou Creek;
- Measurement of the concrete wall rebound using a Schmidt hammer at a number of locations; and,
- Staff interviews.

A summary of the site reconnaissance notes is provided as Appendix C. A summary of key dam dimensions measured during the site reconnaissance is provided in Figure 4.1.

4.2 Visual Inspection

Ecora inspected the concrete gravity dam structure including the spillway, cold joints, height of sediment on the upstream side of the dam, and outlet (creek downstream) of the dam. Photographs 1 through 18 show the Youbou Creek Dam at the time of site visit undertaken on March 28, 2018. The observations made through this inspection are presented in the Photo Log following the text of this report.

Key observations from the site inspection are as follows:

- Five corrugated steel pipe culverts of approximately 1.1 m diameter and up to 6 m length were observed, two beneath the roadway between the stilling basin and the dam and three beneath the roadway downstream of the dam (Photo 3).
- The height to the top of the sediment on the upstream side of the dam varied between 1.27 m and 5.35 m below the dam crest elevation, sediment is lowest in elevation towards the centre of the dam (Photo 5);
- The wall width is approximately 480 mm at the dam crest, the upstream wall face is vertical, the downstream wall face has a back slope of approximately 15° (Photo 9);
- Two cold joints were observed at approximately 1.0 m and 2.7 m vertically below the dam crest (Photo 11, 15);
- The water level at the time of both site visits was above the spillway elevation (Photo 12-14);
- The maximum measured height of the downstream dam face is approximately 8.5 m (Photo 14);
- The spillway is approximately 2.38 m long at an elevation of approximately 760 mm below the dam crest elevation (Photo 14, 17);
- Youbou Creek Dam was formed on bedrock (Photo 18);
- A 300 mm diameter steel low level outlet was observed between the steps and the spillway on the left side of the downstream wall face (Photo 19-20); and,
- The townsite water supply comprises a 150 mm diameter pipe on the right side of the downstream wall face (Photo 19-20).

4.3 Structural Observations

During the visual non-destructive structural assessment of the dam the following key observations were made:

- Signs of moderate weathering, pitting, and erosion of concrete were noted at the waterline (Photo 6).
- Guardrail along crest of dam was noted to be corroded and the stanchion base connections showed signs of movement in some locations (Photo 7).
- Erosion was noted behind the east stoplog channel steel plate (fastened to the side face of the spillway) (Photo 8).
- Horizontal cracking and erosion were noted on the west half of the dam face about 1 m down from the crest of the dam. It was determined that cracks extended through the full width of dam, as water was steadily seeping through the cracks (Photo 11).
- Extensive vegetation was noted throughout the crest and downstream face of the dam (Photo 15).
- A horizontal groove was noted on the east half of the downstream face at about 1.7 m from the crest of the dam along what may have been a construction concrete pour break (Photo 15).
- The downstream face of the dam was heavily eroded/weathered exposing the concrete aggregate throughout (Photo 16).
- Horizontal cracking and erosion were also noted on the east half of the dam face in a similar pattern as the west half, however, no water seepage was noted (Photo 16).

Schmidt hammer rebound values were taken at a number of locations along the dam wall and varied between 8 and 33 with an average reading of 19, corresponding to approximately 10 MPa. It should be noted that given the extent of exposed aggregate at the concrete surface (due to erosion of the concrete paste) and the variability of the values, the rebound values are not considered to have provided an accurate representation of the overall concrete compressive strength. To better understand the in-situ concrete compressive strength, core samples would need to be taken.

4.4 Staff Interviews

Following completion of the site reconnaissance, an interview with David Parker (CVRD) was carried out regarding the operations, maintenance and surveillance of the dam.

Key points from this discussion are as follows:

- Surveillance (inspection) of the dam is undertaken predominantly by the CVRD weekly, weather permitting.

5. Dam Break Analysis

The consequences classification of a dam depends on the incremental consequences of a dam failure, and this can be the result of overtopping, a piping failure, or an earthquake for example. A dam break analysis, including characterization of a hypothetical dam breach, flood wave routing, and inundation mapping, was carried out as part of this review.

Failure times of concrete gravity dams are estimated to be between 6 and 18 minutes (Federal Energy Regulatory Commission, 2015), therefore the characterization of the dam breach and initial flood hydrograph was conducted by assuming a catastrophic failure over the course of 6 minutes during a period of high inflow.

FERC recommends that the average breach width of concrete gravity dams consist of 1 or more monoliths with an average breach width of less than half the length of the dam. However, documentation from FERC further states that higher breach widths should be considered if overtopped for a long period of time. In the case of Youbou Creek Dam it is assumed that the dam consists of one monolith and that the dam would continue to be overtopped until the end of the storm event.

The characterization of the dam breach and initial flood hydrograph was conducted by assuming that the reservoir would rupture during the passage of the 100-year inflow event and that the water in the reservoir is fully discharged during the peak inflow. Due to the small size of the reservoir it was conservatively assumed that water will be discharged fully within the 6 minute failure period. The dam breach parameters are given in Table 5.0.a.

Table 5.0.a Summary of Dam Breach Parameters

Dam Breach Parameter	Value
Type of Dam:	Concrete Gravity
Peak Inflow to Reservoir:	34.2 m ³ /s (100-year flood event)
Water Elevation at Dam Breach:	9.45 m (100-year flood maximum elevation)
Volume of Dam Breach:	2,135 m ³
Reservoir Surface Area:	502.3 m ²
Width of Crest:	0.48 m
Length of Crest:	18.3 m
Time at Which Failure Occurs:	8.1 h
Peak Breach Flow:	7.3 m ³ /s

The resulting dam breach hydrographs were routed using a 2-dimensional volume conservation flood routing model, FLO-2D, with the flood wave simulation run for 24 hours. Topographical inputs for the model were developed from the BC Terrain Resource Information Management (TRIM) Program data supplemented by LIDAR data from the CVRD.

It should be noted that in the FLO-2D model, the ground surface is represented by a grid. The grid size utilized for this project is 5 m × 5 m. This is considered adequate to represent the terrain of the study area. Sudden changes in topographic relief, such as channels, roads and river dykes, may not be accurately characterized at this resolution, as elevation variations are averaged out within a grid area and therefore some localised variation in flow depths from those modelled is anticipated.

The model assumed that any hydraulic structures such as culverts were blocked by debris picked up by the flood wave and therefore their effect on routing the flood wave was ignored.

Changes in the Manning's roughness coefficients in the FLO-2D model due to variations in the flood wave depth, velocity and flow regime are automatically calculated by assigning a limiting Froude number. The Froude number represents the relationship between the kinematic flow forces, gravitational forces and the threshold between subcritical and supercritical flow. Limiting Froude numbers assigned to the grid cells in the analysis are based on the suggested values summarized in Table 5.0.b for various terrain characteristics.

Table 5.0.b Suggested Limiting Froude (Fr) Numbers¹.

Terrain Characteristics	Flat or Mild Slope	Steep Slope
	(large rivers and floodplains)	(alluvial fans and watersheds)
Channels	0.4 – 0.6	0.7 – 1.05
Overland	0.5 – 0.8	0.7 – 1.5
Streets	0.9 – 1.2	1.1 – 1.5

¹ From FLO-2D Reference Manual, September 1996.

Figure 5.0a presents the results of the flood extents and maximum depth of flooding, indicating a total inundation area of 4.2 ha. The flow travels along Youbou Creek for approximately 500 m where it enters Cowichan Lake. It can be noted that most of the flooding can be attributed to the 100-year flood rather than the dam breach due to the relatively small storage volume of the reservoir.

Figure 5.0b shows the delay time between the start of the 100-year rainfall event and the time at which flooding reaches a depth of 0.6 m.

Areas of interest impacted by the dam breach and flooding are summarized below.

- Transportation Infrastructure:
 - Youbou Road;
 - Youbou Community Lane;
 - Cedar Drive;
 - Alder Crescent;
 - Lake Boulevard; and
 - Adelina Lane.
- Residences:
 - Minor Flooding of Downstream Structures.
- Other Potential Impacts:
 - None

Flood hazard maps are presented on Figure 5.0c, using the method of Garcia et. Al (2003 and 2005). The flood hazard level at a specific location is a function of flood intensity (flow depth and velocity) and probability. The map uses three colours to define high (red), medium (orange) and low (yellow) hazard levels. Definitions of each flood hazard are provided in the legend on the map and in Table 5.0.c below.

Table 5.0.c Definition of Water Flood Intensity

Flood Intensity	Maximum Depth “h” (m)		Product of Maximum Depth “h” Time Maximum Velocity “v” (m ² /s)
High	$h > 1.5 \text{ m}$	OR	$v h > 1.5 \text{ m}^2/\text{s}$
Medium	$0.5 \text{ m} < h < 1.5 \text{ m}$	OR	$0.5 \text{ m}^2/\text{s} < v h < 1.5 \text{ m}^2/\text{s}$
Low	$h < 0.5 \text{ m}$	AND	$v h < 0.5 \text{ m}^2/\text{s}$

6. Consequences Classification

6.1 General

A consequences classification system has been developed by the Canadian Dam Association (CDA, 2007) to categorize the consequences of dam failure in terms of potential loss of life; environmental and cultural losses; and infrastructure and economic losses. The consequences classification of a dam should be selected using the highest

rating based on these types of loss. Note that the consequences are incremental to those that would have occurred in the same event without failure of the dam. The CDA (2007) defines incremental consequences of failure as:

“The incremental consequences or damage that a dam failure might inflict on upstream areas, downstream areas or on the dam itself, over and above any losses or damage that may have occurred in the same event or conditions had the dam not failed”.

These consequences categories are applied to establish guidelines for some of the design parameters for a dam, such as the Inflow Design Flood (IDF) and the Earthquake Design Ground Motion (EDGM), and the standard of care expected of owners. The BC Dam Safety Regulation and CDA describes five consequences categories: “Low”, “Significant”, “High”, “Very High” and “Extreme”.

The BC Dam Safety Regulation 40/2016 (February 29, 2016), and the 2007 CDA Dam Safety Review Guidelines (2013 Edition), provide consequences classification criteria as well as suggested design flood and earthquake levels as a function of dam consequences classification as reproduced as Table 6.1 below. It is noted that the BC Dam Safety Regulation was amended in 2011 so that consequences classifications are now in alignment with those provided in the 2007 CDA guidelines and care must be taken in the interpretation of engineering reports dated prior to November 2011.

Table 6.1 Acceptance Criteria for Concrete Gravity Dams

Dam Classification from BC Reg. 40/2016 & CDA 2007	Population at Risk (BC Reg. 40/2016)	Loss of Life (BC Reg. 40/2016)	Infrastructure and Economics (BC Reg. 40/2016)	Environmental and Cultural Losses (BC Reg. 40/2016)	Annual Exceedance Probability Level	
					EQ Design Ground Motion (CDA 2007)	Inflow Design Flood (CDA 2007)
Extreme	Permanent ³	>100	Extremely high economic losses affecting critical infrastructure, public transportation or services or commercial facilities, or some destruction of or some severe damage to residential areas	Major loss or deterioration of: a) critical fisheries habitat or critical wildlife habitat, b) rare or endangered species, c) unique landscapes, or d) sites having significant cultural value, and restoration or compensation in kind is impossible.	1/10,000	PMF
Very High	Permanent ³	10-100	Very high economic losses affecting important infrastructure, public transportation or services or commercial facilities, or some destruction of or some severe damage to residential areas	Significant loss or deterioration of: a) critical fisheries habitat or critical wildlife habitat, b) rare or endangered species, c) unique landscapes, or d) (d) sites having significant cultural value, and restoration or compensation in kind is possible but impractical	½ between 1/2,475 and 1,10,000	¾ between 1/1000 year and PMF
High	Permanent ³	1-10	High economic losses affecting infrastructure, public transportation or services or commercial facilities, or some destruction of or some severe damage to scattered residential buildings	Significant loss or deterioration of: a) important fisheries habitat or important wildlife habitat, b) rare or endangered species, c) unique landscapes, or d) sites having significant cultural value, and restoration or compensation in kind is highly possible	1/2,475	⅓ between 1/1000 year and PMF

Dam Classification from BC Reg. 40/2016 & CDA 2007	Population at Risk (BC Reg. 40/2016)	Loss of Life (BC Reg. 40/2016)	Infrastructure and Economics (BC Reg. 40/2016)	Environmental and Cultural Losses (BC Reg. 40/2016)	Annual Exceedance Probability Level	
					EQ Design Ground Motion (CDA 2007)	Inflow Design Flood (CDA 2007)
Significant	Temporary Only ²	Low potential for multiple loss of life	Low economic losses affecting limited infrastructure and residential buildings, public transportation or services or commercial facilities, or some destruction of or damage to locations used occasionally and irregularly for temporary purposes	No significant loss or deterioration of: a) important fisheries habitat or important wildlife habitat, b) rare or endangered species, c) unique landscapes, or d) sites having significant cultural value, and restoration or compensation in kind is highly possible	1/1,000	Between 1/100 and 1/1000 year
Low	None ¹	0	Minimal economic losses mostly limited to the dam owner's property, with virtually no pre-existing potential for development within the dam inundation zone	Minimal short-term loss or deterioration and no long-term loss or deterioration of: a) fisheries habitat or wildlife habitat, b) rare or endangered species, c) unique landscapes, or d) sites having significant cultural value	1/475	1/100 year

1. There is no identifiable population at risk
2. People are only occasionally and irregularly in the dam-breach inundation Zone, for example stopping temporarily, passing through on transportation routes or participating in recreational activities.
3. The population at risk is ordinarily or regularly located in the dam-breach inundation zone, whether to live, work or recreate

The BC MFLNRORD has currently assigned the dam a consequences classification rating of “Significant” in terms of the BC Dam Safety Regulation (BC Reg. BC Reg. 40/2016). The “Significant” classification suggests that, in the event of a dam failure, no permanent population would be at risk, or there could be significant loss or deterioration of important fish, or wildlife habitat, or high economic losses affecting infrastructure, public transportation and commercial facilities.

6.2 Consequences Classification Review

6.2.1 General

Based on the results of the dam break analysis and flood inundation mapping, a review of the consequences classification criteria for the Youbou Creek Dam was conducted as per the CDA 2007 Dam Safety Guidelines considering each of the following loss criteria:

- Loss of life;
- Environmental and cultural losses; and
- Infrastructure and economics.

It can be noted that the classification rating is based on the potential damage above and beyond that caused by a natural event when the dam does not fail.

6.2.2 Loss of Life

No dwellings were identified within the High Hazard area and therefore no permanent population is considered to be at risk in the event of dam failure. However, it is anticipated that loss of life could occur due to the presence of a transitory population in the inundation zone, for example persons in vehicles on Youbou Road could be impacted by a flood wave in the event of a breach. The breach would therefore only affect a temporary population and corresponds to a consequences classification of “Significant”.

6.2.3 Environmental and Cultural Losses

It is understood that salmon have been identified in the lower reaches of Youbou Creek as indicated by data available through iMapBC. This would indicate that potential loss of minor restorable habitat could occur in the event of the dam breach and thus correspond to a consequences classification rating of “Significant” based on environmental losses.

6.2.4 Infrastructure and Economic Losses

Notable infrastructure within the downstream flood inundation zone includes multiple residential lots along either side of Youbou Creek, Youbou Road, multiple minor roads within Youbou and the Youbou Fire Hall. The loss of Youbou Creek Dam would represent a loss in the ability for the Youbou water system to store water as part of the continued use of the water supply system. It is noted that most of the properties inundated would be impacted during a 100-year flood even if the dam does not fail. It is also noted that these properties exist in areas of medium or low hazard and thus buildings would likely remain intact.

Neither the BC Dam Safety Regulation 40/2016 nor the 2007 CDA Dam Safety Review Guidelines (2013 Edition) provides guidance with respect to the monetary value of infrastructure and economic losses associated with each consequences classification. Therefore, reference has been made to the Ontario Ministry of Natural Resources Technical Bulletin on Classification and Inflow Design Flood Criteria (August 2011) that provides suggested monetary values for economic losses. Table 6.2 below includes the estimated property losses from the technical bulletin for each equivalent CDA consequences classification.

Table 6.2 Property Loss Criteria based on Consequences Classification

Consequences Classification Rating	Economic Losses
Low	Not exceeding \$300,000
Significant	Not exceeding \$3 million
High	Not exceeding \$30 million
Very High & Extreme	In excess of \$30 million

In the event of a dam breach the most notable impact will be the loss of the local water utility's ability to store water. The flood wave also has the ability to overwhelm the downstream culverts as they would need to convey normal flood waters, discharge from the reservoir, debris and any silt eroded from the reservoir in this scenario. It is further anticipated that these culverts wouldn't be able to pass the flow from this combined effect as the stream is unlikely to have sufficient hydraulic capacity for this estimated 100-year event, as indicated by the flood maps generated. Damage to the culverts will include damage to road crossings disrupting vehicle traffic.

The combination of damage to the culverts and the disruption that it would cause likely represent damages greater than \$300,000 but less than \$3 million. The damages are expected to represent low economic losses affecting infrastructure and services and thus would correspond to a consequences classification of "Significant". It is noted that CVRD has explored options to develop wells to help provide drinking water to Youbou and thus the extent of the losses may be reduced in the event of a breach if CVRD were to pursue this option.

6.3 Conclusions

Based on the assessment of the three loss criteria summarised in the sections above, it is recommended that the consequences classification rating of Youbou Creek Dam remain as "Significant". For a dam with a consequences classification of "Significant", the Inflow Design Flood (IDF) is required to be between the 100-year and the 1,000-year event and design seismic hazard is required to be between the 100-year and the 1,000-year event, according to the BC Dam Safety Regulation (BC Reg. 40/2016).

7. Failure Modes Assessment

Static failure of concrete dams can be generally divided into two broad categories, namely:

- Sliding failure; and,
- Overturning failure.

The dam's ability to resist sliding and overturning can be compromised by concrete deterioration and distress. Marginal static stability with respect to sliding, overturning and concrete distress may lead to instability under dynamic loading due to additional loads caused by the inertial effects of the dam and reservoir. The dam foundations may also undergo a loss of strength when subjected to dynamic loading.

Although sliding and overturning stability govern the design of concrete dams, most historical problems are associated with the dam foundations. The foundation of a concrete dam must be capable of resisting the applied forces without overstressing the dam or the foundation itself. The horizontal component of the loads acting on the dam tends to make the dam slide in a downstream direction, which results in shear stresses in the dam and along the base of the dam. These stresses may induce concrete shear failure on horizontal planes within the dam, at the base or along the concrete-rock contact, or within the rock foundation. Uplift forces induced by seepage pressure, in combination with the horizontal forces, tend to overturn the dam, which in turn may cause overstressing and crushing of the rock along the downstream toe of the dam. Increased hydrostatic pressures with the foundation stratum and potential seepage paths may result in piping failure of the foundation due to the filling of the reservoir.

Static concrete dam failures and incidents, as compiled by the US Congress on Large Dams (USCOLD) are summarised in Table below.

Table 7.0 Summary of Causes of Static Concrete Dam Failures

Cause	Failures		Incidents		Total	
	No.	%	No.	%	No.	%
Overtopping	6	31.6	3	15.8	9	23.7
Flow Erosion	3	15.8	0	0	3	7.9
Foundation Leakage, Piping	5	26.3	6	31.6	11	28.9
Sliding	2	10.5	0	0	2	5.3
Deformation & Deterioration	0	0	8	42.1	8	21.1
Other Causes e.g. Faulty Construction, Gate Failure	1	5.3	2	10.5	5	13.1

A modified version of the MFLNRORD Hazard and Failures Modes Matrix (HFMM) to consider other negative human/wildlife interactions beyond terrorism was utilized in assessing the plausible failure modes for Youbou Creek Dam as presented in Appendix D. The likelihood of each hazard and associated failure mode being applicable to Youbou Creek Dam was assessed as either, high, moderate or low as represented by red, orange and green cells respectively in the matrix. It can be noted that the unmodified version uses ratings of applicable versus non-applicable in place of low, medium or high.

For the Youbou Creek Dam, the following failure modes are considered to be plausible:

- **Overtopping** – The water level of the dam during both site visits was above the spillway elevation which is approximately 760 mm below the dam crest elevation;
- **Deformation & Deterioration** – Given the age of the dam it is possible that the concrete wall may have undergone some deterioration; and,
- **Sliding / Overturning Failure** – It is possible that the gravity wall may become unstable when subjected to the design flood / seismic forces.

8. Geotechnical & Structural Assessment

8.1 General

The current assessment is based on the results of the measurements and observations made during the site reconnaissance, available data on the existing dam, published geological data, and Ecora's engineering judgement, rather than a detailed survey and intrusive geotechnical assessment (e.g. drilling, sampling, testing, etc.) and should therefore be considered preliminary in nature. The objective of this approach is to identify potential issues so that any detailed assessment can be tailored to that particular issue.

The following subjects will be discussed in this Section:

- Seepage through the foundation;
- Sliding failure;

- Overturning failure;
- Bearing capacity of the foundation;
- Liquefaction of the foundation and post-earthquake deformation; and,
- Potential for piping through the foundation.

8.2 Material Parameters Estimation

8.2.1 Concrete Gravity Wall

The following assumptions were adopted in the dam stability assessment for the concrete gravity wall:

- Concrete unit weight: 24 kN/m³;
- Concrete compressive strength: 10 MPa; and,
- Concrete is non-porous.

8.2.2 Geotechnical Parameters

Geotechnical parameters for the dam foundation have been estimated using a combination of field observations and published data for similar material types.

Based on our site observations and review of published data for similar material types, the following geotechnical parameters as summarized in Table 8.2 were utilized in the various analyses. It is noteworthy that based on site observations, it is considered likely that the gravity wall is founded on bedrock, however there are no design drawings or geotechnical data to verify this conclusion.

Table 8.2 Summary of Geotechnical Parameters Used in the Dam Assessment

Material	Geotechnical Parameters			
	c' (kPa)	δ (°)	γ (kN/m ³)	k _{sat} (m/s)
Bedrock ^{1,2}	0	35	24	3.2x10 ⁻⁹

1 Concrete-to-bedrock foundation interface friction angle (δ) from Table 24.4 of the CFEM (2006).

2 Saturated hydraulic conductivity (k_{sat}) based on lower bound value for fractured igneous and metamorphic rocks, Figure 5.4 of Wyllie & Mah (2004).

c' = Effective Cohesion Intercept

δ = Interface Friction Angle

γ = Unit Weight

k_{sat} = Saturated Hydraulic Conductivity

8.3 Seepage Through Foundation

At the time of the site reconnaissance there was no obvious seepage flow noted along the dam toe, however it is notable that water was overtopping the spillway at this time which would have made it difficult to assess this.

A steady state seepage analysis was undertaken utilising the built-in Finite Element Analysis (FEA) module within the RocScience Slide v8.017 software. The seepage analysis considered the reservoir level at the spillway elevation

which is consistent with observations during the site reconnaissance. The geometry of the dam has been estimated from measurements obtained during the site reconnaissance. Note that the seepage analysis does not consider flow from concentrated sources such as along the low-level outlet conduit or cracks in the concrete wall or along the base of the gravity wall.

The rate of toe seepage calculated for the dam is summarized in Table 8.3 below. It should be noted that the analyses were undertaken at the dam's maximum height and reduced seepage rates are anticipated where the gravity wall heights are less.

Table 8.3 Estimated Rate of Toe Seepage for the Youbou Creek Dam

Reservoir Level	Calculated Toe Seepage	Figure No.
At spillway elevation	0.0022 m ³ /m/day	8.3

The flow field from the steady state analysis of the dam is provided on Figure 8.3.

8.4 Structural Stability Review

8.4.1 Acceptance Criteria

The CDA Dam Safety Guidelines (2007) provide acceptance criteria for the structural stability of concrete gravity dams including the position of the resultant force for rotational modes of failure, the allowable normal compression strength and minimum factors of safety for resistance to sliding for concrete gravity dams as reproduced in Table 8.4.a below.

Table 8.4.a Acceptance Criteria for Concrete Gravity Dams

Loading combination	Position of resultant force (percentage of base in compression)	Normal compression stress ¹	Sliding safety factor		
			Friction only	Friction and cohesion ² With tests	Without tests
Usual	Preferably within the kern (middle third of the base: 100% compression); however, for existing dams, it may be acceptable to allow a small percentage of the base to be under 0 compression if all other acceptance criteria are met ³	$<0.3 \times f_c'$	≥ 1.5	≥ 2.0	≥ 3.0
Unusual	75% of the base in compression and all other acceptance criteria must be met	$<0.5 \times f_c'$	≥ 1.3	≥ 1.5	≥ 2.0
Extreme flood	Within the base and all other acceptance criteria must be met	$<0.5 \times f_c'$	≥ 1.1	≥ 1.1	≥ 1.3
Extreme earthquake	Within the base, except where an instantaneous occurrence of resultant outside the base may be acceptable	$<0.9 \times f_c'$	Refer to Note 4.		
Post-earthquake	Within the base	$<0.5 \times f_c'$	$\geq 1.1^5$	Refer to Note 6.	

1 Where f_c' = compressive strength of concrete.

- 2 Given the significant impact a very small amount of cohesion can have on the shear resistance of small and medium-sized dams, the use of a cohesive bind this level of safety factor should be used with extreme caution.
- 3 It is very important to verify that all possible failure modes have been addressed under a potential cracked base scenario.
- 4 The earthquake load case is used to establish the post-earthquake condition of the dam.
- 5 If the post-earthquake analysis indicates a need for remedial action, this condition should not be allowed to remain for any length of time. Remedial action should be carried out as soon as possible such that factors of safety are increased to the level of the pre-earthquake conditions.
- 6 Shear resistance based on friction and cohesion needs to be considered carefully, since the analysis surface may not remain in compression throughout the earthquake but may result in cracking, which will change the resistance parameters.

8.4.2 Methodology

The stability review of the gravity wall was undertaken based on the gravity method using rigid body equilibrium to compute factors of safety for the static and seismic stability of the concrete gravity dam.

Because the dam has essentially been constructed in a narrow “V-shaped” channel meaning the wall height varies significantly in a short horizontal distance, the average sliding resistance per metre length of dam has been calculated based on the cross-sectional geometry of the dam at its average height and the total area of sliding interface (including the dam side walls) per metre. The geometry of the dam has been estimated from measurements obtained during the site reconnaissance and scaled from site photos. As there are no design drawings or geotechnical data available for the dam wall, the stability analysis conservatively does not consider foundation embedment or shear key contribution to sliding resistance.

The structural stability analysis considers load conditions at the maximum height of the dam. The operating reservoir level was assumed to be at the spillway elevation (consistent with observations during the site reconnaissance) and the flood elevation was assumed to be at the elevation of the dam crest. The height of sediment against the upstream face of the wall measured on site was used in the analysis assuming active earth pressures, an effective saturated unit weight of 8 kN/m^3 , friction angle of 22° and a wall interface angle of 18° to calculate the silt load.

Due to the assumed low permeability of the bedrock foundation and estimated seepage rate (Section 8.3), uplift pressures beneath the foundation are considered negligible and are therefore not included in the stability analysis with the exception of the post-earthquake load case which assumes a crack has been formed during the earthquake event creating a seepage path and the build up of hydrostatic pressures beneath the dam equal to the hydrostatic head at the upstream and downstream faces.

Pseudo-static stability calculations are based on the 1/1,000 year AEP earthquake design ground motion (EDGM) for a “Significant” consequences dam as recommended by the CDA technical bulletin for Seismic Hazard Consideration for Dam Safety (2007).

A stress analysis for each load case was undertaken utilizing the software program CADAM v.1.4.3 considering loading conditions at the maximum height of the dam to assess whether the normal compression stress at the dam foundation is within the CDA acceptance criteria (Table 8.4.a).

For the purpose of providing a high-level stability analysis and considering the absence of information available on construction of the dam wall, a simplified analysis has been undertaken which does not include the two observed cold joints.

8.4.3 Load Combinations

The following load combinations were considered to assess the stability of Youbou Creek Dam:

- Usual Load Combination: Dead + Operating Hydrostatic + Silt
- Flood Combination: Dead + IDF Hydrostatic + Silt

- Earthquake Combination: Dead + Operating Hydrostatic + Silt + Seismic Load
- Post-Earthquake Combination: Dead + Operating Hydrostatic + Silt + Hydrostatic Uplift

Ice load conditions have not been considered due to the location of the dam.

8.4.4 Results

The results of the stability analysis are summarized in Table 8.4.b and the calculations are provided in Appendix E.

Table 8.4.b Factors of Safety for Stability of the Youbou Creek Dam

Loading condition	Sliding		Overturning		Position of Resultant		Maximum Normal Stress (kPa)
	CDA Min. FoS	Calculated FoS	CDA Min. FoS	Calculated FoS	CDA Limit	Position (% of joint)	
Static stability, operating reservoir level	≥1.5	1.2	≥1.2	1.7	Middle 1/3	84.1	616
Static stability, flood ¹	≥1.1	1.0	≥1.1	1.3	Within base	110.9	809
Pseudo-static stability ²	≥1.0	1.1	≥1.0	1.7	Within base	86.5	1,229
Post-earthquake ³	≥1.1	0.5	≥1.1	0.6	Within base	141.9	540

- 1 Does not consider the effect of debris impact during a debris flood which is considered a potential risk for Youbou Creek Dam.
- 2 The earthquake load case is used to establish the post-earthquake condition of the dam.
- 3 The post-earthquake case assumes a crack has been formed creating a seepage path and the build up of hydrostatic pressures beneath the dam equal to the hydrostatic head at the upstream and downstream faces.

The results indicate that the factors of safety for sliding and the position of the resultant do not meet CDA criteria for the normal, flood and post-earthquake loading combinations. The earthquake loading combination meets or exceeds minimum CDA criteria. The results of the stress analysis indicate that the maximum normal compression stress at the dam foundation meets or exceeds CDA criteria for all the assessed load combinations.

8.5 Gravity Wall Foundation Review

Based on the site observations and the anticipated geological conditions for the site, an allowable bearing capacity of 3 MPa is assumed for the gravity wall foundation as per Table 9.3 of the Canadian Foundation Engineering Manual (CFEM, 2006). The allowable bearing capacity of 3 MPa exceeds the maximum compressive stress for each of the loading conditions considered in the structural stability review as presented in Table 8.4.b above.

8.6 Liquefaction and Post-Earthquake Deformation

Based on site observations, the dam is assumed to be founded on bedrock and is therefore considered to have a very low susceptibility to liquefaction and post seismic deformation when subject to strong ground motion.

8.7 Internal Erosion (Piping)

8.7.1 Internal Erosion Mechanisms

The process of internal erosion through the dam foundation may be broadly divided into four phases, namely:

- Initiation of erosion;
- Continuation of erosion;
- Progression to form a pipe or occasionally cause surface instability (sloughing); and,
- Initiation of a breach.

Erosion can be initiated by four mechanisms, namely:

- Concentrated leaks. Concentrated leaks occur where there is an opening in the foundation through which preferential seepage occurs, with the sides of the opening enlarging through continual erosion by the leaking water. Such concentrated leaks may occur through a crack caused by differential settlement during construction of the dam or its operation, hydraulic fracturing due to low stresses around conduits or the upper parts of the dam due to differential settlement, or through desiccation at high levels of fill. Concentrated leaks can also occur due to collapse settlement of poorly compacted fill around conduits and adjacent to walls. They may also occur due to the action of animals burrowing into levees and small dams and tree roots rotting in dams and forming seepage conduits.
- Backward erosion. Backward erosion piping. Backward erosion piping occurs where critically high hydraulic gradients at the toe of a dam erode particles upwards and internal erosion develops backwards below the dam through small erosion conduits and flow velocity can transport the eroded particles. The presence of backward piping erosion is often exhibited by the manifestation of sand boils at the downstream side of the dam.
- Contact erosion. Contact erosion occurs when a coarse soil such as a gravel is in contact with a fine soil and flow parallel to the contact in the coarse soil erodes the fine soil.
- Suffusion. Suffusion occurs when water flows through widely graded or gap graded (internally unstable) non-plastic soils, with the small particles of soil transported by the seepage flow through the pores of the coarse particles. Poorly graded soils such as non-plastic glacial tills are more vulnerable to suffusion. Suffusion results in an increase in permeability, greater seepage velocities, and potentially higher hydraulic gradients, potentially accelerating the rate of suffusion. Segregation of broadly or gap graded non-plastic soils during dam construction may create layers which are internally unstable even though the average grading of the soil is internally stable.

8.7.2 Piping Potential

As it is assumed that Youbou Creek Dam is founded on bedrock, it is considered to have an extremely low susceptibility to piping failure.

8.8 Debris Flow, Debris Flood and Flood Hazard Assessment

Debris flow, debris flood and flood hazard were studied for the Youbou Creek watershed and assessed using the Melton ratio (Wilford et al., 2004). The Melton ratio was developed to determine whether a stream is likely to be subject to a debris flow, debris flood or a flooding hazard. Debris flows and debris floods represent a significant risk to the dam as debris carried by either a debris flow or debris flood could be sufficient to damage the culverts upstream of the dam and the dam itself.

The sedimentation basin above the dam is intended to capture sediment and debris carried by the flow before reaching the dam, however a large amount of sediment has been observed to have reached the reservoir. The dam itself is also acting as a detention basin, capturing the remaining sediment suspended in the flow. A debris flow or debris flood is likely to overwhelm both of these and will likely pose a risk to the safety of the dam.

Debris flows are very rapid to extremely rapid flows of fully saturated non-plastic (PI < 5% in sand and finer fractions) debris in steep channels (Hungr et al., 2001) that have considerable momentum and high destructive potential with peak discharges of up to 40 times calculated clear water flows. Key characteristics of debris flows include the presence of an established channel or regular confined path and a certain degree of rough sorting that tends to bring the largest clasts close to the flow surface producing inversive grading. Geomorphological indications of channels susceptible to debris flow generation include signs of scour along the gully and the presence of a well-defined depositional cone or fan built up by a number of separate events along the same path.

Debris floods are characterized as sediment-charged flood events with sediment concentrations between 20% and 47% by volume (Hungr et al., 2001) and peak discharges of up to 2 times the calculated flows. Debris floods may be triggered by extreme precipitation events, or by the blockage (and subsequent release) of creek flows impounded by landslides or debris flows entering the creek channel further upstream.

The Melton Ratio is calculated by the equation below:

$$\text{Melton Ratio} = \text{Watershed relief (km)} / \sqrt{\text{Watershed Area (km}^2\text{)}}$$

Watershed relief is the difference in elevation between the top and bottom of the watershed.

Table 8.8 shows the typical ranges of the ratio associated with each hazard type.

Table 8.8 Typical Hazard for Melton Ratios

Hazard	Melton Ratio
Flood	< 0.3 for all watershed lengths
Debris Flood	0.3 to 0.6 for all watershed lengths > 0.6 for watershed lengths \geq 2.7 km
Debris Flow	> 0.6 for watershed lengths < 2.7 km

Note that creeks classified as subject to debris flows may also be subject to floods and debris floods. Those that are subject to debris floods may also be subject to floods but aren't typically subject to debris flows. Those that are classified as subject to floods are typically not subject to debris floods or debris flows.

The Melton ratio calculated for Youbou Creek was 0.6. Plotted against an approximate watershed length of 2 km indicates that the catchment sits on the boundary between debris flows and debris floods as seen in Figure 8.8. This indicates that the catchment could be susceptible to debris floods and debris flows with the flow volumes significantly exceeding those calculated in the hydrotechnical assessment.

9. Hydrotechnical Assessment

The following sections provide a description of the study watershed, a review of available climatic and hydrometric data, and a summary of the method used to develop the Inflow Design Flood (IDF).

9.1 Watershed

Youbou Creek Dam is situated approximately 350 m up Youbou Creek as measured from Youbou Road and has a drainage area of approximately 209 ha based on existing community watershed boundaries. The inflows to the

reservoir are rainfall and snowmelt within the catchment area. The median basin elevation of the Youbou Creek Dam watershed was estimated to be approximately 610 m and the area consists mostly of steep forested slopes. The boundary of the Youbou Creek Dam watershed is presented on Figure 9.1.

9.2 Climatic and Snow Course Data

A number of climate stations operated by the Meteorological Service of Canada (MSC) are located within the study region. In view of their proximity to the project site, elevation and length of record, the following stations were considered to have climatic data that was useful in determining the climate conditions at the project site as summarized in Table 9.2.a with station locations presented on Figure 9.2.

Table 9.2.a Regional Climate Stations

Station Name	Station No.	Elevation (m)	Period of Record	Data Type	Rainfall IDF* Curve	Distance to Site (km)
Lake Cowichan	1012055	171	1983 – 2002	Daily	Yes	13.2
Nanaimo A	1025370	28	1985 – 2012	Daily	Yes	32.0
North Cowichan	1015628	45	1982 – 2005	Daily	Yes	36.7
Victoria Intl A	1018621	19	1965 – 2013	Daily	Yes	62.7
Nanaimo City Yard	1025370	114	1980 – 2007	Daily	Yes	39.6
Cowichan Lake Forestry	1012040	177	1981 – 2010	Daily	No	8.5
Shawnigan Lake	1017230	159	1981 – 2010	Daily	No	50.0
Port Alberni A	1036206	2	1969 – 1993	Daily	Yes	61.2
Port Renfrew	1016335	10	1973 – 1982	Daily	Yes	32.8

*Intensity – Duration – Frequency data

According to the 1981 to 2010 Climate Normals data on the Environment Canada website, the mean annual precipitation at the Lake Cowichan Station, which is located at the east end of Cowichan Lake, is 2,047.5 mm (1,975.6 mm rainfall and 72.0 cm snowfall). Rainfall occurs throughout the year with 80% of the rainfall occurring between the months of October and March. Snowfall mainly occurs in the winter months of December, January and February, snowfall has been recorded between the months of October and May. Mean daily temperatures range from 2.5°C in December to 18.1°C in August. The rainfall-frequency data for the Lake Cowichan, Nanaimo A and North Cowichan stations are shown in Table 9.2.b and the 24-hour rainfall totals for various return periods were obtained from IDF curves available through the MSC. The stations Victoria Intl A, Nanaimo City Yard, Cowichan Lake Forestry, Shawnigan Lake, Port Alberni A and Port Renfrew were included for the purposes of determining a temperature elevation relationship of the area to be applied in the snowmelt calculation. The 500-year, 1000-year and 5000-year 24-hour rainfall totals were obtained by extrapolation and adjusted to apply to the project site based on the elevation-rainfall relationship for the regional climate stations in Table 9.2.b.

Table 9.2.b Rainfall Intensity Frequency Data at Regional Climate Stations

Return Period (Years)	24-Hour Rainfall Total (mm)		
	Lake Cowichan	Nanaimo A	North Cowichan
2	93.6	55.5	57.8
5	110.7	69.7	70.8
10	122.1	79	79.4
25	136.4	90.9	90.3
30	138.9	92.9	92.2
50	147.2	99.8	98.5
100	157.6	108.4	106.5
500	184.5	130.6	126.9
1000	195.8	139.9	135.5
5000	221.9	161.5	155.3

The River Forecast Centre of the BC Ministry of Environment has a number of snow course and snow pillow sites available on Vancouver Island. The station closest to the project site, by distance and elevation, is the Jump Creek snow pillow station (at an elevation of 1160 m) located north of the dam. The information for this automatic snow pillow station is presented in Table 9.2.c.

Table 9.2.c Regional Snow Pillow Station

Station Name	Station No.	Elevation	Period of Record	Distance to Site
Jump Creek Snow Pillow Station	3B23P	1160 m	1995 – 2011	12.3 km

The average snow water equivalents for the period of record at the Jump Creek snow pillow station are summarized in Table 9.2.d.

Table 9.2.d Average Snowpack Data for Jump Creek Snow Pillow

Month	Snow Water Equivalent (mm)
Jan	580.6
Feb	836.1
Mar	1070.2
Apr	1257.5
May	1015.6
June	308.5

The data shows the peak average snow water equivalent (1257.5 mm) occurs in April. Note that this station is approximately 920 m higher than Youbou Creek Dam, so use of this data is considered conservative.

9.3 Hydrometric Data

There is no long-term streamflow data available within the Youbou Creek watershed. Regional hydrometric data was obtained from the Water Survey of Canada to characterize the hydrology of the study area. The regional hydrometric stations used in this study are listed in Table 9.3 with station locations presented on Figure 9.3.

Table 9.3 Regional Hydrometric Stations

Station ID	Station Name	Drainage Area (km ²)	Period of Record	Status
Cottonwood Creek Headwaters	08HA072	3.81	1998 – 2018	Active
Harris Creek Near Lake Cowichan	08HA070	28.0	1997 – 2018	Active

9.4 Determination of Inflow Design Flood

9.4.1 General

Based on a review of dam consequences classification discussed in Section 6.2, Youbou Creek Dam should be classified as a “Significant” consequences dam in accordance with the 2007 Canadian Dam Association (CDA) Dam Safety Guidelines (2013 Edition). The CDA guidelines for an Inflow Design Flood (IDF) for a “Significant” consequences dam is between the 100-year event and the 1000-year event. For the study watershed, peak runoffs are generated either by major rainstorms alone or by rain-on-snow events.

9.4.2 Determination of the 1,000-Year Flood

Two methods were used to determine the 1000-year flood: a rainfall-runoff approach and a regional analysis. The rainfall-runoff approach refers to the development of a hydrologic model to determine the runoff hydrograph at the site, using precipitation and snowmelt as inputs. The regional analysis involves frequency analyses of regional hydrometric data and determination of the relationship between peak discharge and size of drainage area. The following paragraphs further illustrate the methodology and present the results of the two approaches.

Rainfall-Runoff Approach

The 1000-yr 24-hour rainfall totals were calculated using a regression analysis from available 24-hour rainfall data at the Lake Cowichan, Nanaimo A and North Cowichan stations. The elevations and the magnitude of the 1000-year rainfall events are included in Table 9.4.a.

Table 9.4.a 1000-Year 24-Hour Rainfall

Station Name	Elevation (m)	1000-Year 24-Hour Rainfall (mm)
Lake Cowichan	171	195.8
Nanaimo A	28	139.9
North Cowichan	45	135.5

A relationship between 1000-year 24-hour rainfall and elevation was developed using the above results to calculate the corresponding rainfall at the project site. The calculated 1000-year 24-hour rainfall at the site was estimated to be 381 mm.

To take into account the snowmelt occurring during a rain-on-snow event, the following equation was applied (Gray, 1973):

For heavily forested regions (60 – 100%)

$$M = (0.074 + 0.007 * P) * (T_a - 32) + 0.05$$

where

M = snowmelt (in/day);

P = precipitation (in); and

T_a = temperature (°F).

For the 1000-year flood, the 1000-year 24-hour rainfall and the average daily temperature from January to March was used in estimating the daily snowmelt rate. The average value of the mean daily temperature (4.3°C) at Youbou Creek Dam was calculated by defining a relationship for average temperature based on elevation for the above referenced climate stations and using that relationship to estimate the temperature at the Youbou Creek Dam. The average daily snowmelt during a 1000-year rainfall event was determined to be 36.4 mm/day. This daily snowmelt is considered reasonable when compared to the Jump Creek snow pillow station data because there would be enough snow to supply the calculated amount of snowmelt. The combination of the 1,000-year 24 hour precipitation and snowmelt amounts to 417 mm.

The hydrologic model used in the runoff analysis was HEC-HMS version 4.0, developed by the U.S. Army Corps of Engineers. The US Soil Conservation Service (SCS) unit hydrograph method was applied to determine the runoff hydrograph from the 1000-year 24-hour rainfall combined with the average daily snowmelt rate. The SCS Type Ia distribution was selected to define the distribution of rainfall over 24 hours. The average daily snowmelt was evenly distributed and combined with the rainfall for the storm of interest. In general, the Youbou Creek catchment area consists of heavily forested areas in good condition. Soil Type B, representing soil with a well-drained and moderately well-drained infiltration rate, was chosen for the study area. Antecedent moisture condition III (saturated

conditions) was assumed. A curve number (CN) of 79 was estimated for the catchment area. Slopes, elevations and channel lengths were taken from GIS maps to estimate the time of concentration for the catchment.

The peak inflow to Youbou Creek Dam during the 1000-year return period flood was estimated to be 42.3 m³/s.

Regional Analysis

A regional hydrological analysis was carried out to provide an alternative estimate of the 1000-year flood inflow to Youbou Creek Dam. Flood frequency analyses were conducted for the selected regional hydrometric stations using the HYFRAN software Version 2.2. Four different frequency distributions: Gumbel, the Three Parameter Lognormal, Weibull and the Log Pearson Type III distributions, were applied to the data. The maximum instantaneous flows were plotted against drainage area and a regression equation was fitted to obtain the 1000-yr flows for each selected hydrometric station. The peak flow estimates for three return periods at the project site are tabulated in Table 9.4.b.

Table 9.4.b Regional Analysis Peak Flood Estimates

Return Period (Years)	Flood Estimates (m ³ /s)
10	9.8
30	10.2
50	11.3
100	13.7
200	14.7
500	14.5
1000	17.0
5000	17.8

1000-year Flood

The 1000-year peak flood estimate obtained from the regional analysis is lower than that from the hydrologic model. However, most of the available regional stations with data sets extensive enough for statistical analysis are from larger watersheds than that of Youbou Creek. As larger watersheds have a greatly reduced peaking factor and significantly larger time of concentration, it is likely that this method underestimates flooding within the watershed. Also, the data sets within the regional analysis mostly have too short of period of records for accurate statistical assessment of a 1000-year event. The HEC-HMS hydrologic model was based on site specific conditions such as soil type and local climate data, making this method preferred as well as conservative. Therefore, the 1000-year peak inflow to Youbou Creek Dam was determined as 42.3 m³/s.

9.4.3 Inflow Design Flood

The rainfall-runoff method is considered appropriate for developing the IDF for Youbou Creek Dam as it accounts for site specific conditions such as soil type and local climate data.

As indicated earlier, the 1000-year flood event was determined to be 42.3 m³/s. The 100-year flood was further determined with the above methodology to provide the boundary of the inflow event for a “Significant” consequences dam. The CDA guidelines recommend that the IDF for a “Significant” consequences dam should be between 100-year and the 1,000-year event (CDA 2007).

The peak inflow to Youbou Creek Dam during the IDF was determined to be between 34.2 m³/s (100-year event) and 42.3 m³/s (1,000-year event). The hydrographs for calculated return periods are shown on Figure 9.4.

9.5 Flood Routing and Freeboard Determination

A hydrological model was developed to simulate water levels in the Youbou Creek reservoir and determine the peak outflow during the IDF. The following sections provide a summary of the methodology and results of this analysis.

9.5.1 Volume-Elevation Relationship

The volume-area-elevation relationship for Youbou Creek Dam was estimated using measurements at the time of the field reconnaissance. The reservoir was observed to have a large volume of sediment built up behind the dam, so the current storage capacity is limited. The area of the reservoir at the spillway was estimated at 460 m² with a storage capacity of 1,770 m³ if it is assumed that the reservoir is clear of sediment. The estimated storage capacity should be treated as approximate only as the numbers used in the calculation are based on limited measurements. The estimated area-elevation-storage relationship is illustrated in Figure 9.5a.

There is a sedimentation basin above the dam, however it is unable to trap all the sediment coming from upstream.

9.5.2 Rating Curve

As part of the field reconnaissance completed by Ecora the spillway crest length was determined to be 2.38 m with a height of 0.76 m. The geodetic elevation of the spillway is currently unknown as Ecora was unable to get accurate survey data during the field reconnaissance. The rating curve for the spillway was estimated based on the following equation (Smith, 1995):

For broad crested weir flow:

$$Q = CLH^{1.5}$$

Where:

Q = Discharge (m³/s);

C = Discharge coefficient;

L = Effective spillway crest length (m); and

H = Head above spillway crest (m).

The concrete dam crest will also act as a weir if the flood overtops the dam and it has likely done so in the past as evidenced by wear along the crest of the dam. The rating curve developed for the Youbou Creek Dam spillway is shown on Figure 9.5b. The capacity of the spillway, to the dam crest, is 2.7 m³/s.

9.5.3 Flood Routing Results

The flood routing was performed using the HEC-HMS model, which includes a routing component for flows through reservoirs. The starting water surface elevation was assumed to be at the spillway crest elevation and for conservative results it was assumed that the low level outlets were not operating. It is noted that due to large sediment deposits within the reservoir it is reasonable to expect that the low level outlets would be ineffective at discharging any remaining storage volume. The results of the HEC-HMS flood routing during the IDF corresponding to the "Significant" classification as well as other notable flows are summarized in Table 9.5. Figure 9.5c represents the results of the flood routing graphically.

Table 9.5 Results of Flood Routing

Consequences Classification/ Return Period	Spillway Weir Crest Local Elevation (m)	Initial Reservoir Level (m)	Peak Reservoir Level (m)	Peak Storage (1000 m ³)	Peak Inflow (m ³ /s)	Peak Outflow (m ³ /s)	Dam Crest Local Elevation (m)	Available Freeboard (m)
30-year	7.74	7.74	9.37	0.8	30.2	30.2	8.5	-0.9
50-year	7.74	7.74	9.40	0.8	32.0	31.9	8.5	-0.9
100-year	7.74	7.74	9.45	0.8	34.2	34.2	8.5	-1.0
500-year	7.74	7.74	9.57	0.9	39.9	39.9	8.5	-1.1
Significant (1000-year)	7.74	7.74	9.62	0.9	42.3	42.3	8.5	-1.1
5000-year	7.74	7.74	9.73	1.0	47.8	47.8	8.5	-1.2

The results above indicate that for the “Significant” consequences storm that there is overtopping of the dam. The reservoir level response to the IDF is plotted in Figure 9.5d. Peak outflows would reach between 34.2 m³/s and 42.3 m³/s for storm events for the “Significant” consequences storm. Note that the results for other return periods are included for comparison only, as it has been established the “Significant” is the appropriate classification.

9.5.4 Wind and Wave Considerations

Wind and wave analyses were not undertaken for this dam as the concrete structure is considered non-erodible and thus should be able to resist overtopping without serious damage. The CDA Guidelines (2007) indicate that concrete dams may be permitted to have freeboard requirements reduced or overtopping may be allowed provided that the integrity of the dam, its abutments and any ancillary structures is not compromised.

9.5.5 Freeboard Assessment

The flood routing exercise described above determined that during the IDF event the dam crest will be overtopped. Given that Youbou Creek Dam is a concrete gravity dam, it should be able to resist overtopping without serious damage and given the wear pattern on the dam, it has likely overtopped in the past. The CDA Guidelines (2007) indicate that concrete dams may be permitted to have the freeboard requirement reduced or overtopping may be allowed provided that the integrity of the dam, its abutments and any ancillary structures is not compromised. It can be noted that safe access to control structures may not be maintained in the event of an overtopping event due to the placement of control valves below the dam crest.

10. Dam Safety Management System

10.1 General

Dam safety management can be generally described in terms of five components (CDA Guidelines 2007):

- Owner commitment to safety;
- Regular inspections and Dam Safety Reviews with proper documentation and follow up;
- Implementation of effective Operations, Maintenance and Surveillance (OMS) practices;
- Preparation of effective Emergency Preparedness Plan; and
- Management of Public Safety.

A general schematic of a dam safety management system is presented in Figure 10.1. Ecora has assessed the dam safety management system in place for the Youbou Creek Dam and the results of this assessment are presented in this section.

10.2 Operations, Maintenance and Surveillance Manual

An Operations, Maintenance and Surveillance (OMS) Manual is a means to provide both experienced and new staff with the information they need to support the safe operation of a dam (CDA 2007). It is Ecora's understanding that currently Youbou Creek Dam does not have an Operations, Maintenance and Surveillance Plan.

10.3 Dam Emergency Plan

The objective of a Dam Emergency Plan (DEP) is to establish a formal internal document that operators of a dam should follow in the event of an emergency at the dam. The DEP outlines the key emergency response roles and responsibilities, in order of priority, as well as the required notifications and contact information. The DEP also provides basic information that allows for the planning and coordination by municipalities, Royal Canadian Mounted Police, Provincial agencies, utility owners, transportation companies and other parties that would be affected by a major flood (CDA 2007). The DEP is intended to combine the requirements of both the Emergency Response Plan (ERP) and Emergency Preparedness Plan (EPP) based on the BC Dam Safety Regulation (40/2016).

It is Ecora's understanding that currently Youbou Creek Dam does not have a DEP.

10.4 Public Safety Management

The CDA released Guidelines for Public Safety around Dams in 2011. Public safety around dams is an emerging topic in the dam safety community around the world, which in Canada is led by the CDA.

Dam owners are responsible for managing the public safety risks caused by a dam, as far upstream and downstream as the owner has property rights. Beyond the property the dam owner may have additional responsibilities to assess specific locations where the hazards are known by the owner to result directly from the dam or its operation and to inform the public and other affected property owners of these hazards. In most jurisdictions in Canada, due diligence is the test that the dam owner has taken reasonable and prudent precautions to protect the public. The implementation of a Public Safety Plan (PSP), records of decisions made, and activities performed to manage public safety at the dam, provide evidence of due diligence (CDA 2011).

During Ecora's inspection of Youbou Creek Dam it was noted that there is limited restriction on public interaction with the dam, with some evidence of ground disturbance or vandalism noted. Currently there is no PSP in place for this facility.

10.5 Dam Safety Expectations Assessment

10.5.1 General

The British Columbia Ministry of Forests, Lands, Natural Resource Operations & Rural Development (MFLNRORD) has developed a sample check sheet of Dam Safety Expectations, Deficiencies and Priorities (May 2010) which is based on the BC Hydro Hazards and Failures Modes Matrix and the 2007 CDA Guidelines. A dam safety expectations assessment has been undertaken for Youbou Creek Dam using the sample check sheet prepared by the MFLNRORD as presented in Appendix F.

The Dam Safety Expectations are divided into five categories:

- Dam Safety Management System
- Operations, Maintenance and Surveillance
- Emergency Preparedness
- Dam Safety Review
- Dam Safety Analysis

A brief summary of the results of the Dam Safety Expectations is discussed below.

10.5.2 Dam Safety Analysis

There are three actual deficiencies and one non-conformance.

Deficiencies:

- Catchment may be susceptible to the formation of debris flows and debris floods and thus the dam may not be adequately protected.
- Spillway is undersized and will overtop in extreme flow events.
- Dam does not have adequate freeboard as the spillway is undersized and will overtop in extreme flow events.

Non-conformances:

- No engineering drawings of the dam structure were available. Limited inspection and operational records are available.

10.5.3 Operations, Maintenance and Surveillance

There is one actual deficiency and 17 non-conformances.

Deficiencies:

- Low level outlets at the base of the dam will be difficult to access if the dam is spilling or being overtopped.

Non-conformances:

- All non-conformances could be addressed with the completion of an OMS Plan that includes detailed operating procedures, testing records, training records and surveillance documentation.

10.5.4 Emergency Preparedness

There are no deficiencies and 10 non-conformances in this category which can be addressed by documenting training and by the completion of an DEP.

10.5.5 Dam Safety Review

There are no deficiencies and non-conformances in this category. By commissioning this Dam Safety Review the Cowichan Regional District conforms to the dam safety expectations for this category.

10.5.6 Dam Safety Management

There are no deficiencies and seven non-conformances in this category all of which could be addressed with a completion of a OMS Manual and a DEP.

11. Risk Assessment

11.1 General

As part of the DSR, the NDMP Risk Assessment Information Template (RAIT) was completed by Ecora in accordance with NDMP and has been attached in Appendix G. The assessment process allows stakeholders to identify and prioritize the risks that are likely to create the most disruption to them. The assessment also helps decision-makers to identify and describe hazards and assess impacts and consequences based upon the vulnerability or exposure of the local area, or its functions to that hazard.

The risk assessment approach aims to understand the likely impacts of a range of emergency scenarios upon community assets, values and functions. As such, risk assessments provide an opportunity for multiple impacts and consequences to be considered enabling collaborative risk treatment plans and emergency management measures to be described.

The outputs of the assessment process can be used to better inform emergency management planning and priority setting, introduce risk action plans, and ensure that communities are aware of and better informed about hazards and the associated risks that may affect them.

11.2 Risk Assessment Information

Descriptions of the risk ranking, and definitions associated with the five-point scale used to define the impacts are presented below. The impact risk rating definitions are based on qualitative and quantitative elements referenced from a diverse array of risk and resilience methodologies and external risk management models.

People and Societal Impacts

It is a priority at the municipal, provincial and federal levels to protect the health and safety of Canadians. Impacts on people are considered pertinent in the assessment process given that natural hazards can result in significant societal disruptions such as evacuations and relocations as well as injuries, immediate deaths, and deaths resulting from unattended injuries or displacement. As such, the following impact criteria will be assessed on a 1 to 5 scale:

- number of fatalities;
- ability for local healthcare resources to address injuries; and,
- number of individuals displaced and duration of displacement.

Environmental Impacts

A priority for municipal, provincial and federal governments is to protect Canada's natural environment for current and future generations. As such, environmental impacts were included in the assessment to measure the risk event in relation to the degree of damage and predicted scope of clean-up and restoration needed following an event. The definitions consider the direct and indirect environmental impacts within the defined geographic area on a 1 to 5 scale, and include an assessment of air quality, water quality and availability (exclusive to on land and in-ground water), and various other nature indicators.

Local Economic Impacts

There may be impacts on the local economy that are the result of a risk event occurring. Local economic impacts attempt to capture the value of damages or losses to local economically productive assets, as well as disruptions to the normal functioning of the community/region's local economic system. The definitions consider the local economic impacts within the defined geographic area on a 1 to 5 scale and should consider direct and indirect economic losses (i.e. productivity losses, capital losses, operating costs, financial institutions and other financial losses).

Local Infrastructure Impacts

There are several local infrastructure components, as per a variety of risk assessment and management sources and guidelines that are fundamental to the viability and sustainability of a community/region. Those components that appear most pertinent to assess impacts resulting from natural hazards, such as floods, include: energy and utilities; information and communication technology; transportation; health, food and water; and safety and security. At a minimum, an assessment of the aforementioned components must be completed, defined on a 1 to 5 scale, and should consider both direct and indirect impacts.

Public Sensitivity Impacts

Public sensitivity was included as an impact criterion given that credibility of governments is founded on the public's trust that all levels of government will respond effectively to a disaster event. The definitions consider the impacts on public visibility on a 1 to 5 scale and include an assessment of public perception of government institutions, and trust and confidence in public institutions.

11.3 Risk Assessment Summary

From the impact categories considered, the following principal impacts were noted:

- The primary risk event is the breach of Youbou Creek Dam due to structural failure due to hydrostatic pressures generated by a 1 in 30-year flood event.
- In the event of a dam breach, significant damage to public infrastructure would occur including damage to the following"
 - Dam and sedimentation basin access road,
 - Youbou Road,
 - Side streets subject to surface flooding,
 - Arbutus Park
 - Bus stop for Youbou connector (Bus Number 20), and

- Youbou Fire Department.
- The event would most likely occur in the cold part of the year (October to March) as most rainfall falls within these months.

11.4 Confidence Levels

The risk assessment process requires confidence levels to be defined, particularly since confidence levels can vary considerably depending on the availability of quality data, availability of relevant expertise to feed the risk assessment process, and the existing Canadian body of knowledge associated with specific natural hazards and natural disaster events.

Confidence levels have been defined using letters ranging from A to E, where 'A' is the highest confidence level and 'E' is the lowest. This approach was taken to ensure all applicants can determine the confidence in their risk assessment in a simplified, straightforward manner, which also ensures that a more consistent representation of confidence levels is being determined across all submissions.

The level of confidence for this assessment is considered to be "C", based on the level of assessment completed to date.

12. Observations and Conclusions

The conclusions reached during the DSR of Youbou Creek Dam are presented as follows for each area of review:

12.1 Background Review

- Limited background information is available for this dam and does not include record drawings for the dam structure.
- The dam was constructed at some point prior to 1959.
- No obvious signs of historical or current slope instability of the reservoir side slopes were observed in the review of available photographs.

12.2 Site Reconnaissance

- The reservoir and sedimentation basin were both filled with sediment at the time of the site reconnaissance.
- Vegetation is currently growing out of the face of the dam.
- Concrete is showing significant wear on the downstream face.

12.3 Consequences Classification Review

- The dam breach inundation mapping indicates that a total area of approximately 1.05 km² would be flooded in the event of a dam breach during a 100-year event, potentially impacting Youbou Road and properties downstream.

- Dam breach analysis and inundation mapping results confirmed that the consequences classification for Youbou Creek Dam should be maintained as “Significant”. The CDA guidelines recommend an Inflow Design Flood (IDF) for a “Significant” consequences dam to be between the 100-year and the 1,000-year event.

12.4 Failure Mode Assessment

- The plausible failure modes of the dam are; overtopping as the spillway may become blocked with debris, deformation & deterioration due to age and sliding/overturning failure from the design flood or seismic forces.

12.5 Geotechnical & Structural Assessment

- Results of the stability assessment indicate that the dam does not meet CDA structural stability criteria for normal, flood and post-earthquake loading conditions. The earthquake load combination meets or exceeds minimum CDA criteria.
- The allowable bearing capacity of the foundation is adequate to resist the maximum compressive stress for normal, flood, earthquake and post-earthquake loading conditions.
- The dam foundation is considered to have a very low susceptibility to liquefaction and post seismic deformation when subject to strong ground motion.
- The dam foundation is considered to have an extremely low susceptibility to piping failure.
- The calculated Melton Ratio for Youbou Creek was determined to be 0.6 which indicate that the creek may be susceptible to the formation of debris flows, debris floods and floods.

12.6 Hydrotechnical Assessment

- The peak inflow to Youbou Creek Dam during the IDF associated with the recommended “Significant” consequences classification is between 34.2 m³/s (100-year) and the 42.3 m³/s (1,000-year). Because of the absence of significant storage, peak outflows are the same.
- The spillway does not have adequate capacity to pass the IDF associated with the “Significant” consequences classification.
- The capacity of the spillway is estimated to be 2.7 m³/s.
- The flood routing exercise determined that during the IDF event the dam crest will be overtopped. Given that Youbou Creek Dam is a concrete gravity dam, it should be able to resist overtopping without serious damage and given the wear pattern on the dam, it has likely overtopped in the past.

12.7 Dam Safety Management

- An Operations, Maintenance and Surveillance Manual and a Dam Emergency Plan need to be prepared for Youbou Creek.

12.8 Risk Assessment

- The dam does not meet current CDA requirements in terms of sliding and overturning and thus failure of the dam may occur due to conditions expected over a 30-year period corresponding to an NDMP rating of 1.
- A preliminary estimate of reconstruction costs as a result of a dam breach is between \$300,000 and \$3 million based on the scope of the infrastructure impacted.

13. Recommendations

The recommendations that have been developed during this DSR of Youbou Creek Dam are presented as follows for each area of review. Priorities (Low, Medium, High or Very High) are given in parentheses. Low, medium, high and very high priority recommendations should be addressed within 5, 3, 1 and 0.5 year(s) respectively.

13.1 Background Review

- As no record drawings are available for the dam structure, a detailed topographical survey of the dam embankment, abutments, outlet and spillway channel should be commissioned to verify existing dam geometry, confirm critical dam elevations and to assist in any future engineering assessments (High).

13.2 Site Reconnaissance

- If CVRD would like to continue to use the dam for drinking water purposes it is recommended that the sediment be removed from the reservoir to restore the available storage capacity (Low).

13.3 Consequences Classification Review

- There are no recommendations in this area of the review.

13.4 Failure Mode Assessment

- There are no recommendations in this area of the review.

13.5 Geotechnical and Structural Assessment

- CVRD should commission a design study to address the major deficiencies in the Youbou Creek Dam, namely to increase its resistance to sliding and overturning to meet CDA stability criteria or alternatively decommission the dam. It is envisioned this would result in a recommendation to remediate the existing dam that would likely include the design of a reinforced concrete toe buttress to increase the stability of the gravity wall (Very High).
- If it is chosen to remediate the existing dam, it is recommended that areas of concrete deterioration particularly in vicinity of cold joints are addressed.

- Remediation or decommissioning of the existing dam should consider the potential impacts of debris floods and debris flows as the existing sediment basin and reservoir provides some mitigation of this hazard to the community of Youbou.

13.6 Hydrotechnical Assessment

- Extra spillway capacity should be added to the dam to allow for passage of the IDF event or the dam should be strengthened so that the dam would be able to resist forces generated by an overtopping event during the IDF (High).

13.7 Dam Safety Management

- An Operation, Maintenance and Surveillance Manual and a Dam Emergency Plan need to be prepared for Youbou Creek Dam (High).
- The dam should either be decommissioned or rehabilitated to meet design loading criteria (High).

13.8 Risk Assessment

- Should the CVRD wish to proceed with a NDMP funding application to remediate or replace Youbou Creek Dam they should undertake a more detailed cost estimate of infrastructure that would be impacted in the event of a dam breach (High).

14. Dam Safety Review Assurance Statement

In accordance The Association of Professional Engineers and Geoscientists of BC (APEGBC) Professional Practice Guidelines – Legislated Dam Safety Reviews in BC V3.0 (October 2016) we have completed a Dam Safety Review Assurance Statement, which is presented in Appendix H.

References

- ASCE/USCOLD, 1975. Lessons from Dam Incidents.
- Ardiaca, D.H., 2009. Mohr-Coulomb Parameters for Modelling of Concrete Structure. Plaxis Bulletin - Spring Issue 2009.
- Association of Professional Engineers and Geoscientists of BC (APEGBC), 2016. Professional Practice Guidelines – Legislated Dam Safety Reviews in BC V3.0.
- British Columbia Ministry of Environment, 2012. Dam Safety Review Guidelines. – Version 3.
- Canadian Dam Association (CDA), 1997. Dam Safety Guidelines.
- Canadian Dam Association (CDA), 2002. Dam Safety Review Workshop, 2002 CDA Conference, Victoria, British Columbia.
- Canadian Dam Association (CDA), 2007. Dam Safety Guidelines 2013 Edition.
- Canadian Dam Association (CDA), 2007. Technical Bulletin – Dam Safety Analysis and Assessment.
- Canadian Dam Association (CDA), 2007. Technical Bulletin – Geotechnical Considerations for Dam Safety.
- Canadian Dam Association (CDA), 2007. Technical Bulletin – Hydrotechnical Considerations for Dam Safety.
- Canadian Dam Association (CDA), 2007. Technical Bulletin – Inundation, Consequences and Classification for Dam Safety.
- Canadian Dam Association (CDA), 2007. Technical Bulletin – Seismic Hazard Considerations for Dam Safety
- Canadian Dam Association (CDA), 2011. Guidelines for Public Safety around Dams.
- Environment Canada, 2014. Historical Climate Data. <http://climate.weather.gc.ca/>
- Fell, R., MacGregor, P., Stapledon, D., and Bell, G., 2005. Geotechnical Engineering of Dams. CRC Press.
- FLO-2D, 2011. FLO-2D Grid Developer System (GDS) Pro Manual.
- Garcia, R., López, J.L, Noya, M.E., Bello, M.T., González, N. Paredes, Vivas, M.I. & O'Brien, J.S., 2003. "Hazard mapping for debris flow events in the alluvial fans of northern Venezuela." Third International Conference on Debris-Flow Hazards Mitigation: Mechanics, Prediction and Assessment. Davos, Switzerland. September 10 12.
- Garcia, R. & López, J.L, 2005. "Debris Flows of December 1999 in Venezuela." Chapter 20th of Debris-flow Hazards and Related Phenomena. Jakob, Matthias, Hungr, Oldrich Eds. Springer Verlag Praxis, Berlin.
- Goda Y., 1988. On the Methodology of Selecting Design Wave Height. Proceedings of the Coastal Engineering Conference, Malaga, Spain, ASCE, 899-913.
- Halchuk, S.C., Adams, J.E., and Allen, T.I. 2015. "Fifth generation seismic hazard model for Canada: Grid values of mean hazard to be used with the 2015 National Building Code of Canada". Geological Survey of Canada Open File 7893.
- Hogg, W. D. and D.A. Carr, 1985. Rainfall Frequency Atlas for Canada.
- Ministry of Forest, Land and Natural Resource Operation, 2014. River Forecast Centre, Automated Snow Pillow Data. <http://bcrcfc.env.gov.bc.ca/data/asp/>

Singhal B.B.S, and Gupta, R.P., 2010. Applied Hydrogeology of Fractured Rocks, Second Edition.

Smith C.D., 1995. Hydraulic Structures.

USBR, 1999. A Procedure for Estimating Loss of Life Caused by Dam Failure. DSO-99-06

Water Survey of Canada, 2012. Archived hydrometric data: <http://www.wsc.ec.gc.ca/applications/H2O/index-eng.cfm>.

Figures

Figure 1.2a	Site Plan
Figure 1.2b	General Site Location & Access Routes
Figure 3.4	Bedrock Geology
Figure 4.1	Estimated Dimensions of Youbou Creek Dam
Figure 5.0a	Extent of Inundation & Maximum Flow Depth
Figure 5.0b	Time (Hrs) for 0.6 m Flow Depth
Figure 5.0c	Flood Hazard Rating
Figure 8.3	Steady State Seepage Analysis: Reservoir Level at Spillway Elevation
Figure 8.8	Melton Ratio of Youbou Creek
Figure 9.1	Youbou Creek Watershed
Figure 9.2	Climate and Automated Snow Pillow Stations
Figure 9.3	Hydrometric Stations
Figure 9.4	Inflow Design Flood Hydrographs
Figure 9.5a	Youbou Creek Dam Area Elevation Storage Curves
Figure 9.5b	Youbou Creek Dam Spillway Rating Curve
Figure 9.5c	Youbou Creek Dam Flood Routing Hydrographs
Figure 9.5d	Youbou Creek Dam Reservoir Flood Levels
Figure 10.1	Dam Safety Management System

DAM SAFETY REVIEW AND RISK ASSESSMENT OF YOUBOU CREEK DAM YOUBOU, BC

Legend

- Youbou Creek Dam
- 100m TRIM Contours
- Fresh Water Atlas Streams
- Digital Atlas Roads
- Highways
- Dam Access Road

LOCATION MAP

1:3,000

Meters

Project No.: GK-18-020-CVD
 Client: Cowichan Valley Regional District
 NAD 1983 UTM Zone 10N

Date: 2018/11/19
 Drawn: MT Check: AG

Figure 1.2a



GENERAL SITE LOCATION & ACCESS ROUTES



DAM SAFETY REVIEW AND RISK ASSESSMENT OF YOUBOU CREEK DAM YOUBOU, BC

Legend

- Youbou Creek Dam
- Highways
- Route 1 - 30 min (40.9km)
- Route 2 - 1 h 44 min (79.7km)

LOCATION MAP

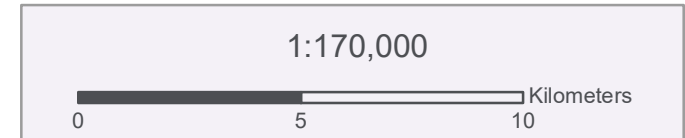
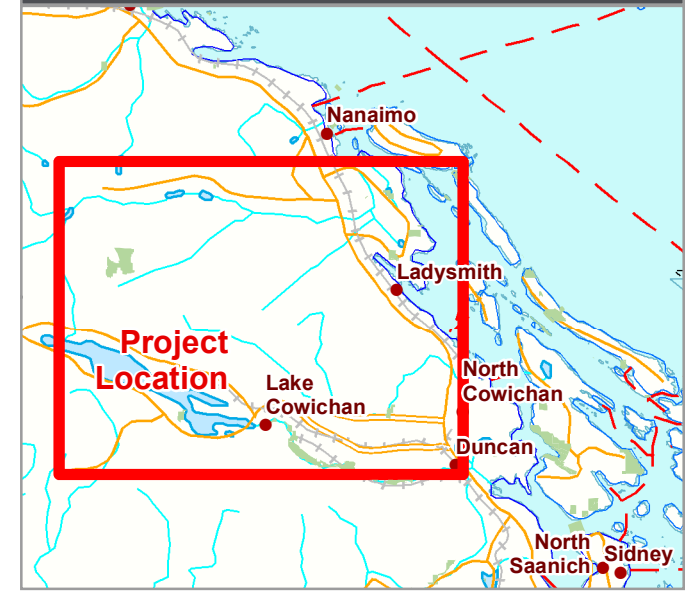

Project No.: GK-18-020-CVD Date: 2018/11/16
Client: Cowichan Valley Regional District Drawn: MT Check: AG
NAD 1983 UTM Zone 10N

Figure 1.2b

DAM SAFETY REVIEW AND RISK ASSESSMENT OF YOUBOU CREEK DAM YOUBOU, BC

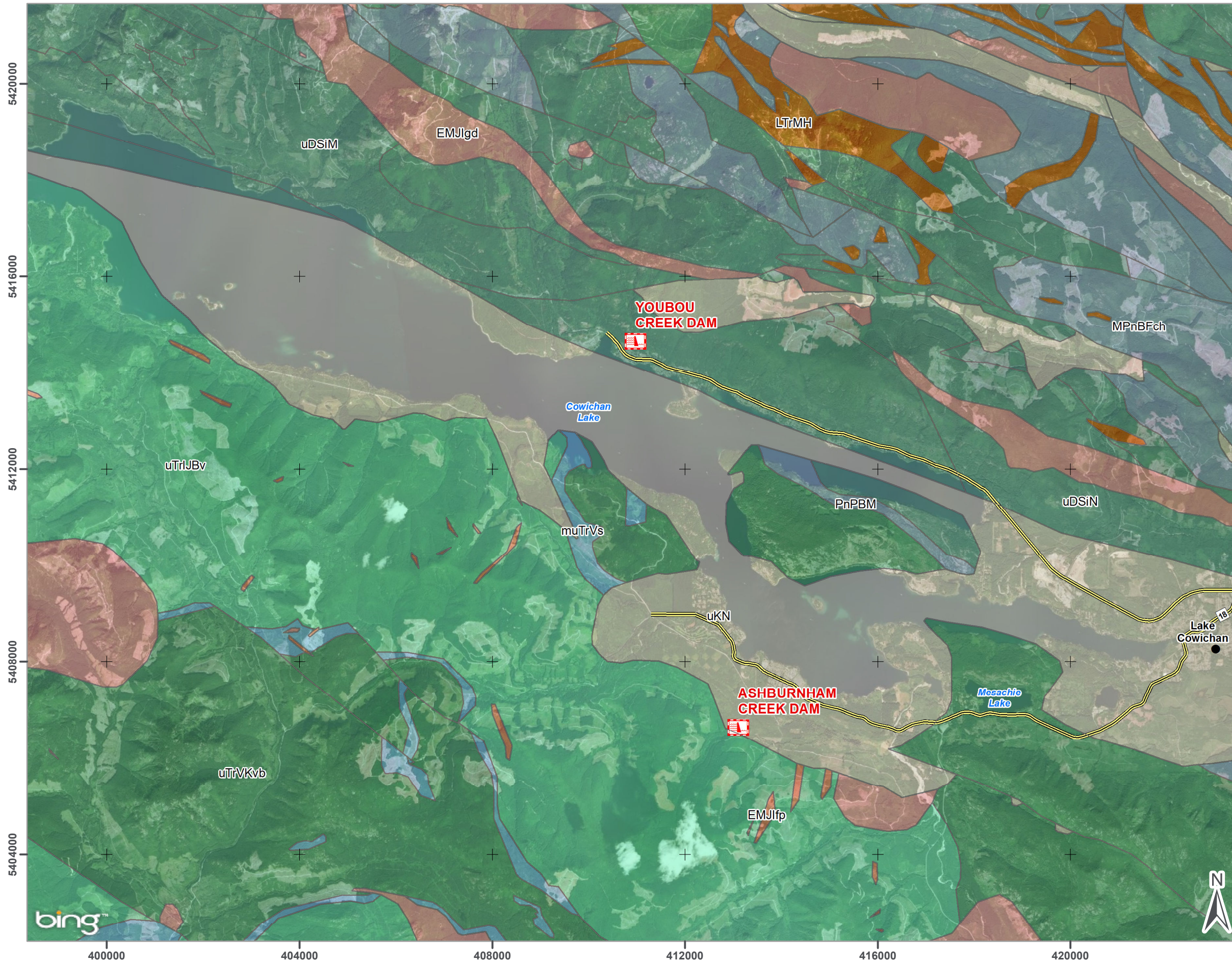

Legend

- Cities
- Dam Locations
- Highways
- Streams

Bedrock Geology

- EMJlfp - Feldspar porphyry, hornblende porphyry, augite porphyry, dacite, basalt (92B, C, F).
- EMJlgd - Granodiorite, quartz diorite, quartz monzonite, diorite, agmatite, feldspar porphyry, minor gabbro and aplite (170 - 185 Ma).
- LTrMH - Gabbro, diabase, feldspar diabase, glomeroporphyritic diabase and gabbro, minor diorite (215 - 230 Ma). Coeval with Karmutsen Formation.
- MPnBFch - Ribbon chert, cherty tuff, graphitic argillite, thinly bedded intercalated sandstone-siltstone-argillite, volcanic sandstone and conglomerate, interbedded argillite and crinoidal limestone, massive and pillowed basalt with intercalated cherty sed
- PnPBM - Massive crinoidal limestone, bedded calcirudite and calcarenite, chert, cherty argillite and siltstone, marble (Upper Pennsylvanian to Lower Permian) (92B, C, F)
- muTrVs - Undifferentiated Parson Bay and Quatsino formations (92B, C, F).
- uDSiM - Thickly bedded tuffite and lithic tuffite, breccia, tuff, feldspar and quartz-feldspar crystal tuff, lapilli tuff, rhyolite, dacite, laminated tuff, jasper, chert, hematite-chert iron formation (92B, C, F).
- uDSiN - Pyroxene-feldspar phyrlic agglomerate, breccia, lapilli tuff, massive and pillowed flows, massive tuffite, laminated tuff, jasper and chert (92B, C, F)
- uKN - Boulder, cobble and pebble conglomerate, coarse to fine sandstone, siltstone, shale, coal (Santonian to Maastrichtian). Includes BENSON, COMOX, HASLAM, EXTENSION, PENDER, PROTECTION, EAST WELLINGTON, TRENT RIVER, CEDAR DISTRICT, DE COURCY, DE
- uTrVKvb - Basalt pillowed flows, pillow breccia, hyaloclastite tuff and breccia, massive amygdaloidal flows, minor tuffs, interflow sediment and limestone lenses (Carnian).
- uTrJBv - Massive amygdaloidal and pillowed basalt to andesite flows, dacite to rhyolite massive or laminated lava, green and maroon tuff, feldspar crystal tuff, breccia, tuffaceous sandstone, argillite, pebble conglomerate and minor limestone (Sinemurian t

1:80,000

Project No.: GK-18-020-CVD Date: 2018/11/02
 Client: Cowichan Valley Regional District Drawn: MT Check: AG
 NAD 1983 UTM Zone 10N

Figure 3.4

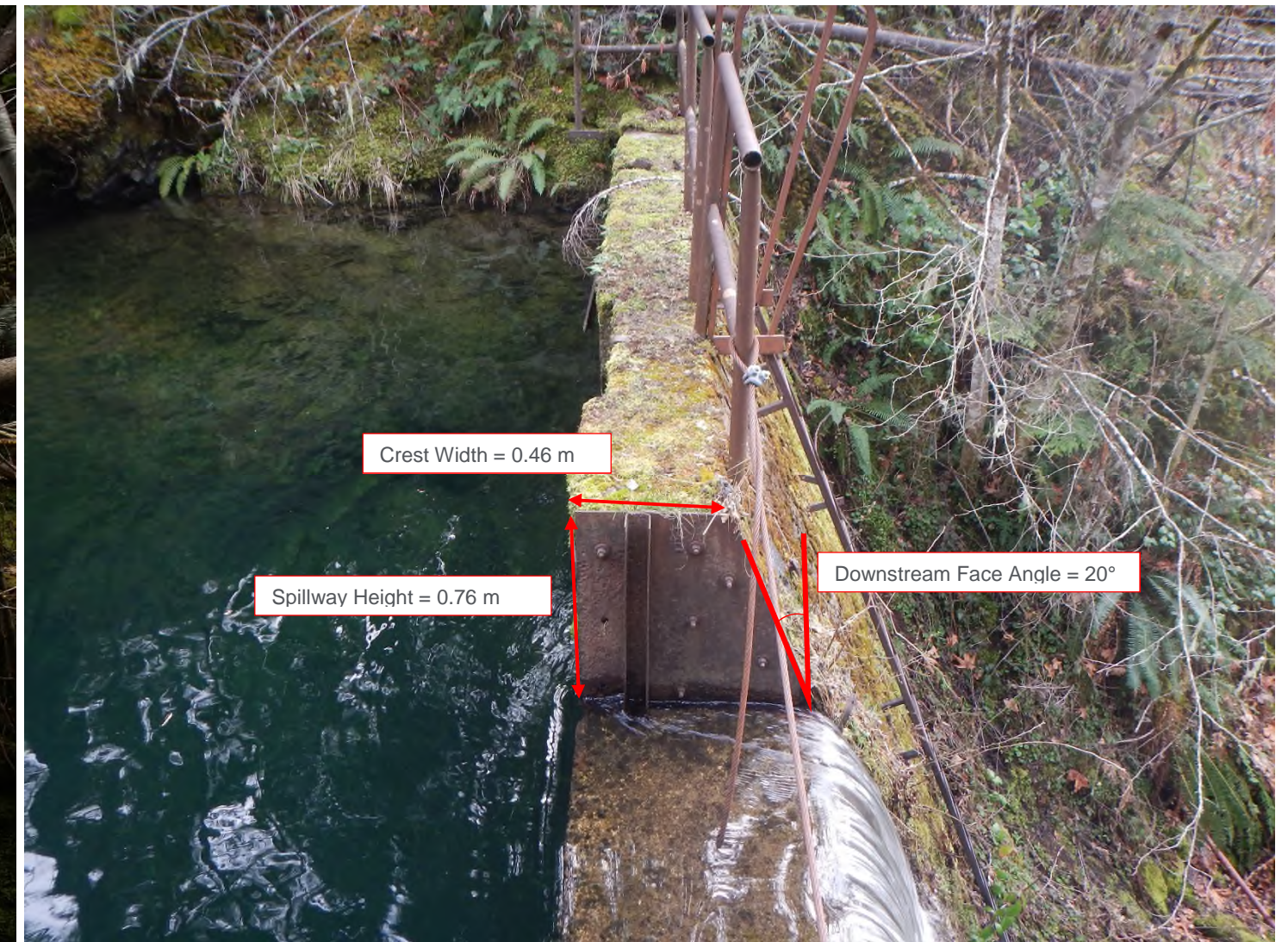
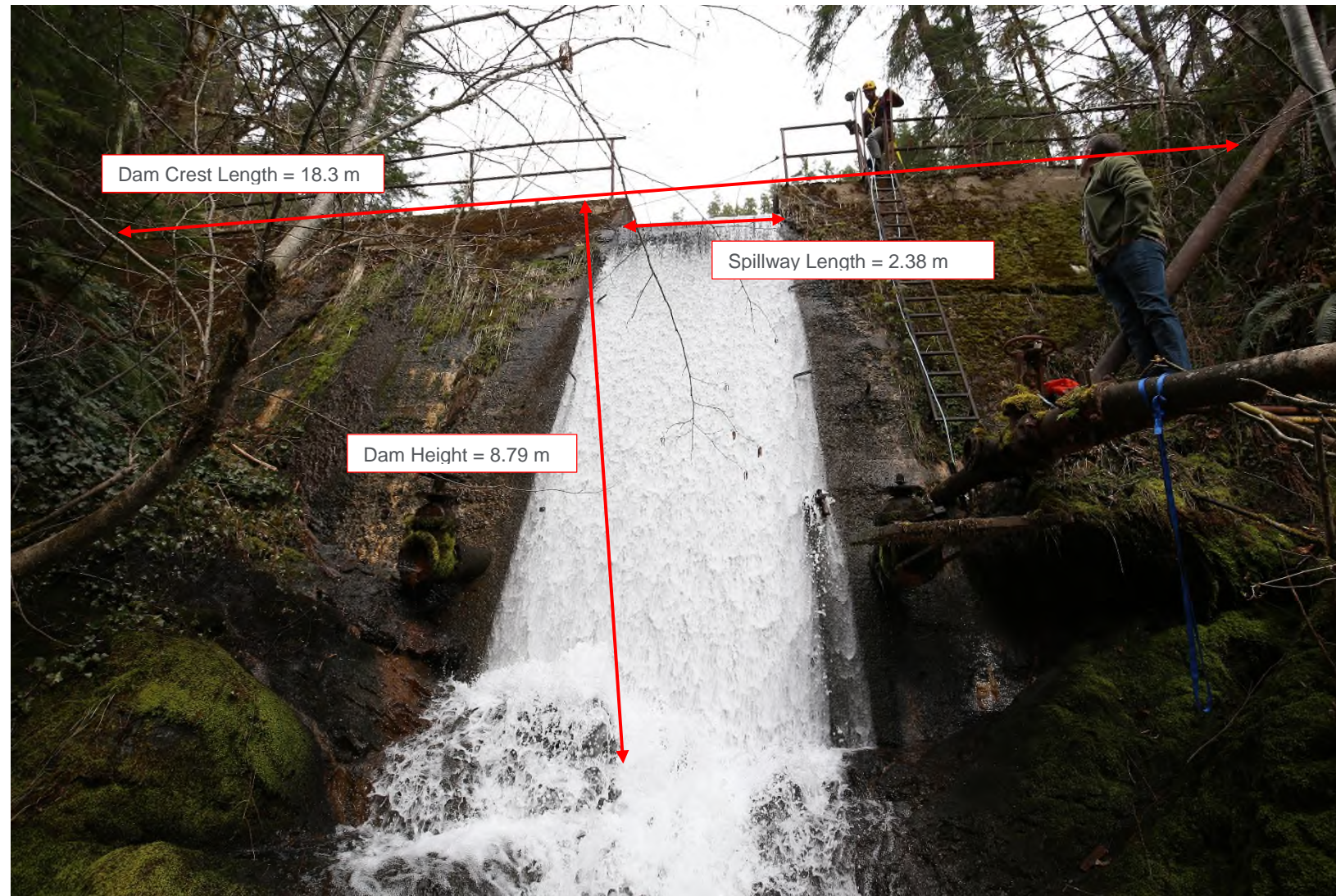

Notes:
Photos taken on March 3, 2018.

DAM SAFETY REVIEW AND RISK ASSESSMENT OF YOUBOU CREEK DAM

Estimated Dimensions of Youbou Creek Dam

Project No. GK-18-020-CVD
 Client: Cowichan Valley Regional District
 Office: Kelowna
 Scale: NTS
 Date: JAN 10, 2019
 DWN: AG CHK: MJL



Figure 4.1

EXTENT OF INUNDATION & MAXIMUM FLOW DEPTH

DAM SAFETY REVIEW AND RISK ASSESSMENT OF YOUBOU CREEK DAM YOUBOU, BC

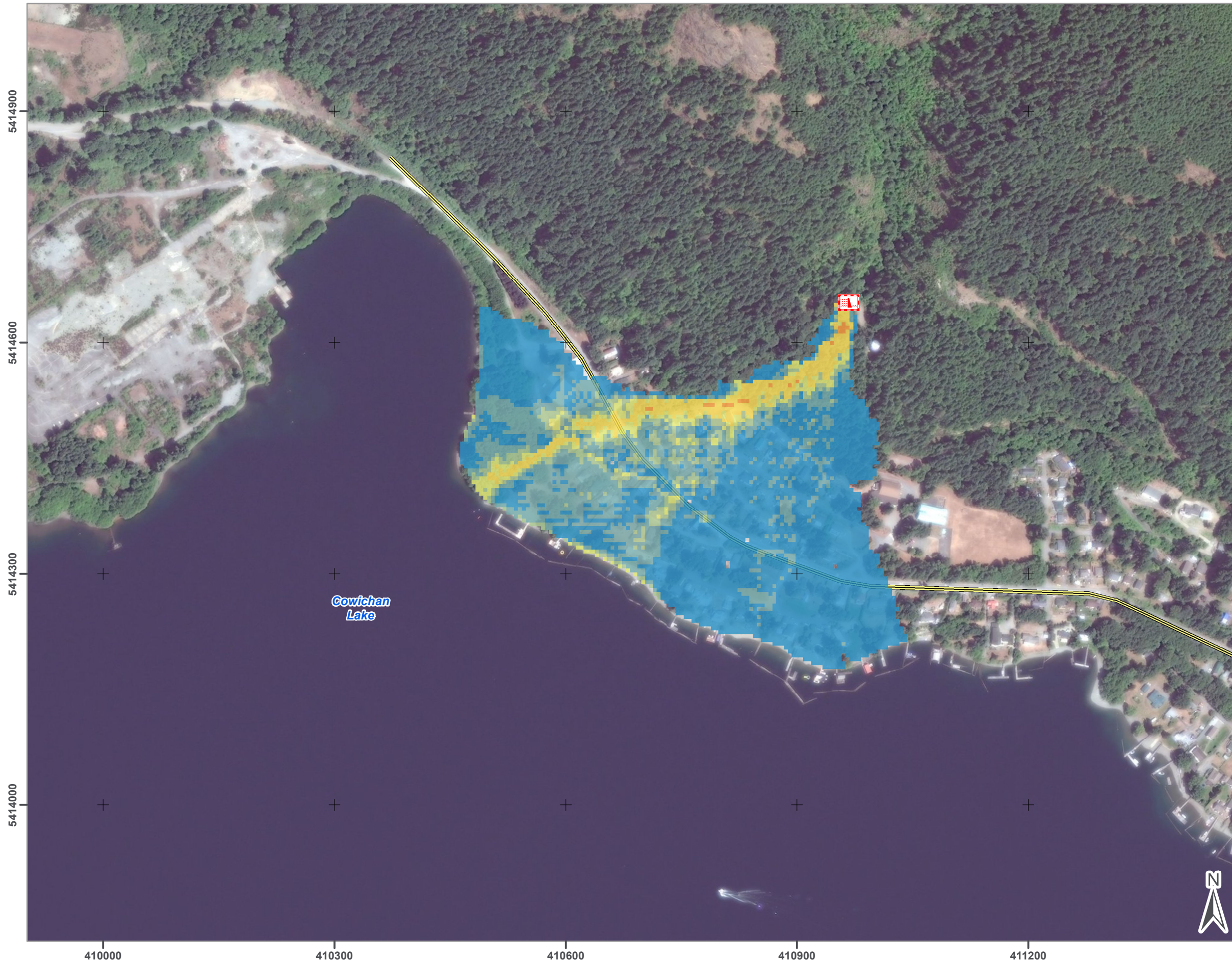

Legend

- Youbou Lake Dam Location
 - Assumed Residence
 - Other Building
- Maximum Flow Depth (m)
- 0.000 - 0.250
 - 0.251 - 0.500
 - 0.501 - 0.750
 - 0.751 - 1.000
 - 1.001 - 2.000
 - 2.001 - 4.000
 - 4.001 - 6.000
 - 6.001 - 8.000

Total Area of Inundation = 0.16 km²

LOCATION MAP

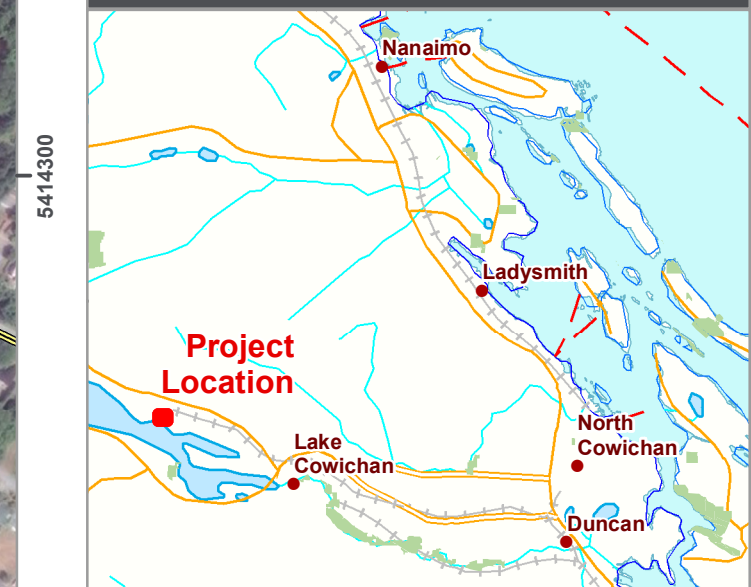

1:5,000

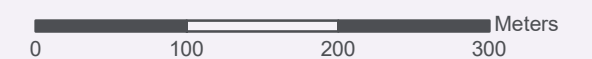

Project No.: GK-18-020-CVD
Client: Cowichan Valley
Regional District
NAD 1983 UTM Zone 10N

Date: 2018/11/19
Drawn: MT Check: AG

Figure 5.0a

TIME (HRS) FOR 0.6m FLOW DEPTH

DAM SAFETY REVIEW AND RISK ASSESSMENT OF YOUNBOU CREEK DAM YOUNBOU, BC



Legend

- Youbou Lake Dam Location
- Assumed Residence
- Other Building

Time (hrs) for 0.6m Flow Depth

- 0.100 - 1.000
- 1.001 - 3.000
- 3.001 - 5.000
- 5.001 - 7.000
- 7.001 - 9.000
- 9.001 - 10.000
- 10.001 - 15.000

LOCATION MAP

Project No.: GK-18-020-CVD Date: 2018/11/19
 Client: Cowichan Valley Regional District Drawn: MT Check: AG
 NAD 1983 UTM Zone 10N

Figure 5.0b

FLOOD HAZARD RATING

DAM SAFETY REVIEW AND RISK ASSESSMENT OF YOUNBOU CREEK DAM YOUNBOU, BC

Legend

- Youbou Lake Dam Location
- Assumed Residence
- Other Building

Flood Hazard Rating and Total Area of Flooding Downstream of Dam Spillway

- Low (0.016km²)
- Medium (0.022 km²)
- High (0.0042 km²)

Hazard Level	Description
High	Persons are in danger both inside and outside of buildings. Structures are at risk of being destroyed.
Medium	Persons are in danger outside of buildings. Structures may suffer damage and possible destruction depending on construction characteristics.
Low	Danger to persons is low or non-existent. Buildings may suffer little structural damage, however may undergo significant non-structural damage to interiors.

Reference: Garcia, et al., 2003, 2005

LOCATION MAP

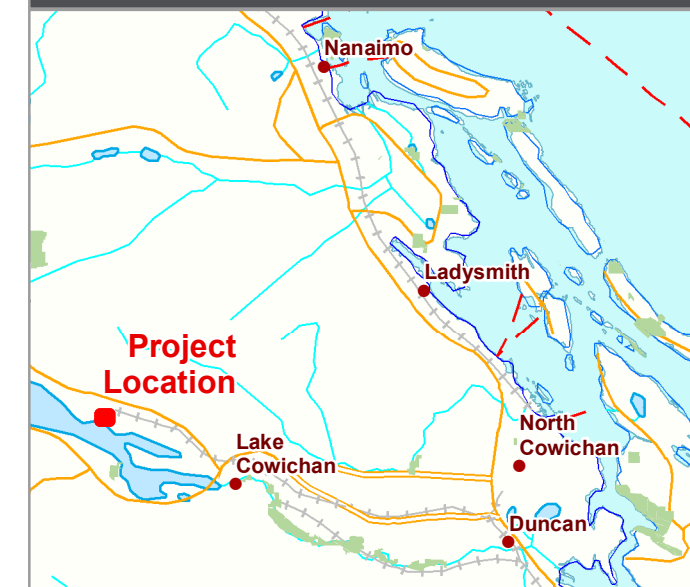

1:5,000



Project No.: GK-18-020-CVD
Client: Cowichan Valley
Regional District
NAD 1983 UTM Zone 10N

Date: 2018/11/19
Drawn: MT Check: AG

Figure 5.0c



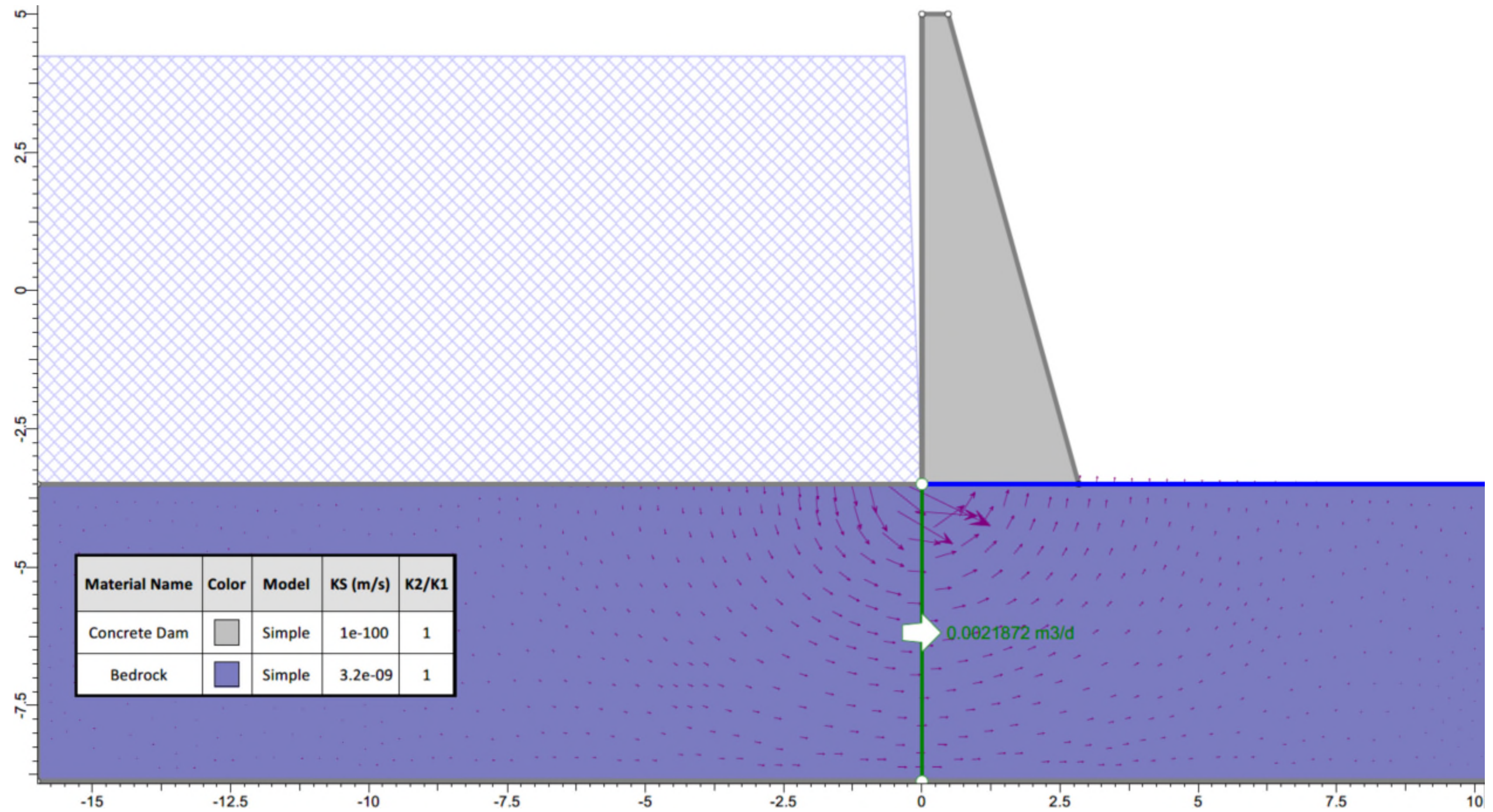

Notes:

DAM SAFETY REVIEW AND RISK ASSESSMENT OF YOUNG CREEK DAM

Steady State Seepage Analysis: Reservoir Level at Spillway Elevation

Project No. GK-18-020-CVD
 Client: Cowichan Valley Regional District
 Office: Kelowna
 Scale: NTS
 Date: November 5, 2018
 DWN: CE CHK: MJL



Figure 8.3

Melton Ratio Classification

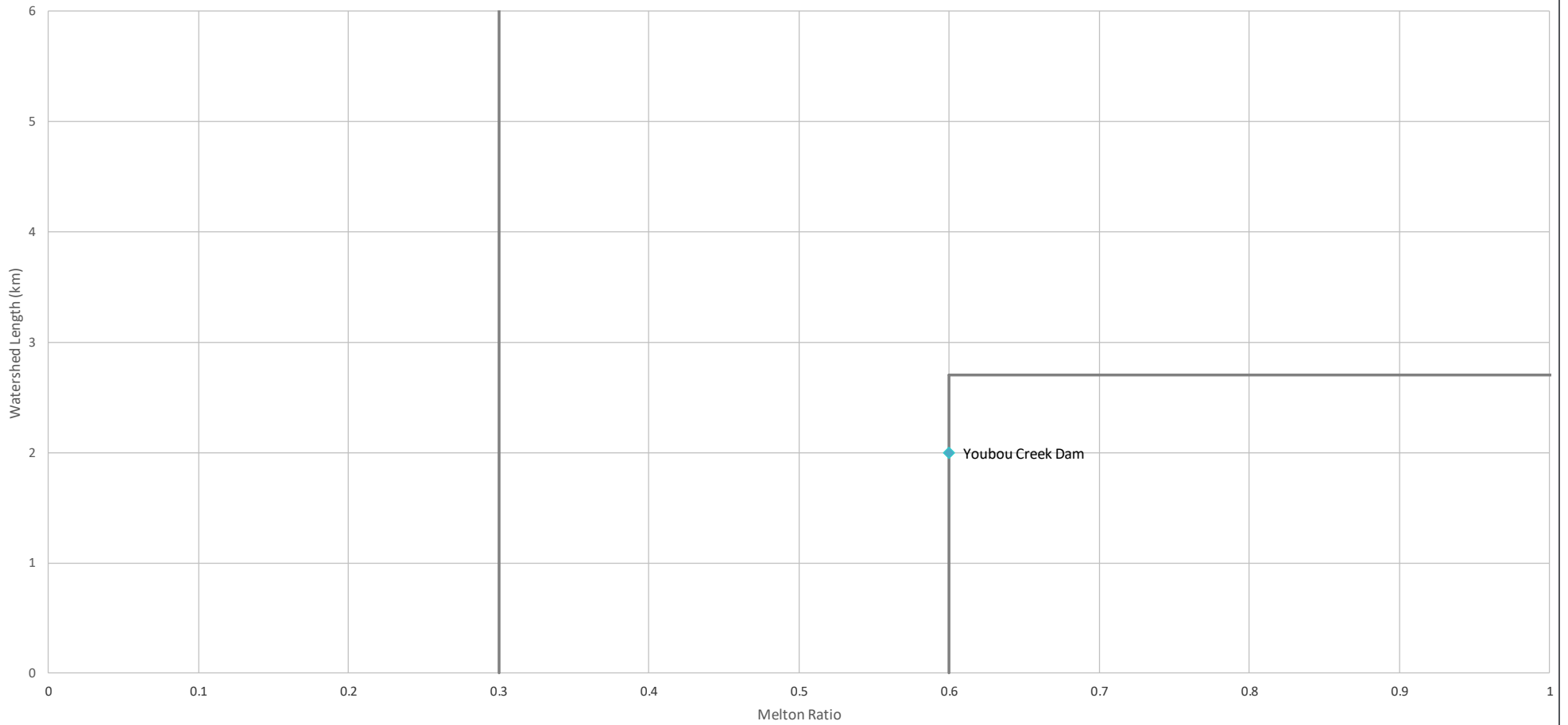

Notes:

DAM SAFETY REVIEW AND RISK ASSESSMENT OF YUBOU CREEK DAM

Melton Ratio of Youbou Creek

Project No. GK-18-020-CVD
Client: Cowichan Valley Regional District
Office: Kelowna
Scale: NTS
Date: OCT 31, 2018
DWN: AG CHK: MJL









Figure 8.8

YOUBOU CREEK WATERSHED



DAM SAFETY REVIEW AND RISK ASSESSMENT OF YOUBOU CREEK DAM YOUBOU, BC

Legend

-  Youbou Creek Dam
-  100m TRIM Contours
-  Fresh Water Atlas Streams
-  Digital Atlas Roads
-  Highways
-  Youbou Community Watershed

LOCATION MAP

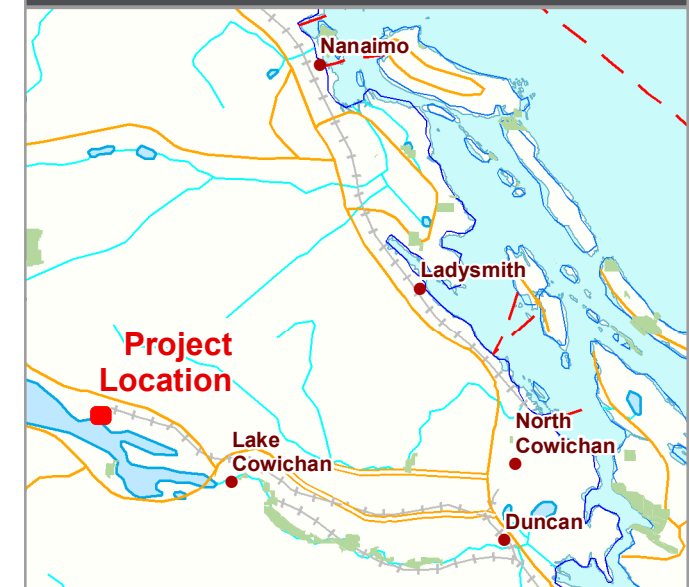

1:12,000

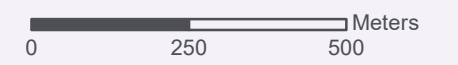

Project No.: GK-18-020-CVD
 Client: Cowichan Valley Regional District
 NAD 1983 UTM Zone 10N

Date: 2018/11/02
 Drawn: MT Check: AG

Figure 9.1

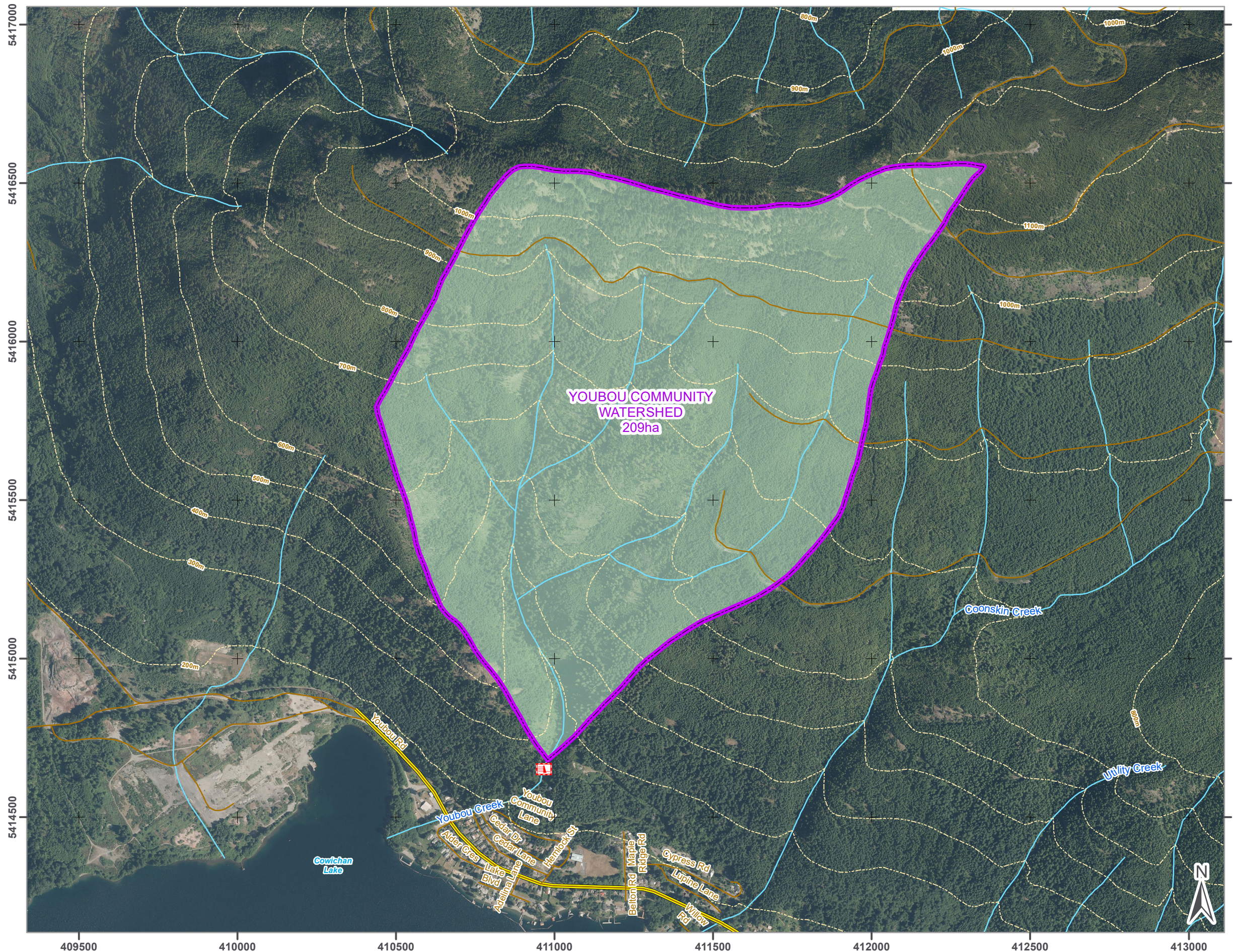

DAM SAFETY REVIEW AND RISK ASSESSMENT OF YOUNG CREEK DAM YOUNG, BC

Legend

- Cities
- Climate Station (Environment and Climate Change Canada)
- Automated Snow Pillow Station (British Columbia)
- Highways
- Streams
- - - Ferry Route
- Roads
- Trail
- Bridge
- Reserves
- Parks

LOCATION MAP

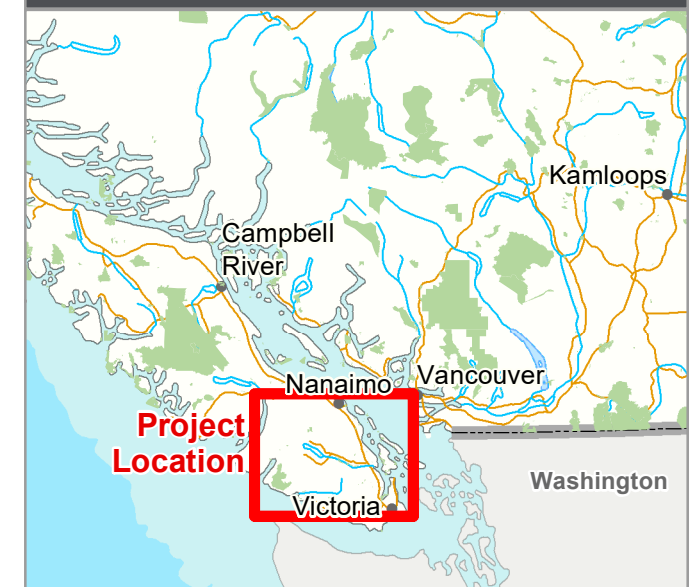

1:400,000

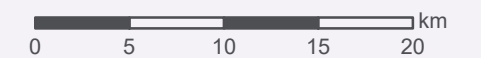

Project No.: GK-18-020-CVD Date: 2018/11/19
 Client: Cowichan Valley Regional District Drawn: MT Check: AG
 NAD 1983 UTM Zone 10N

Figure 9.2

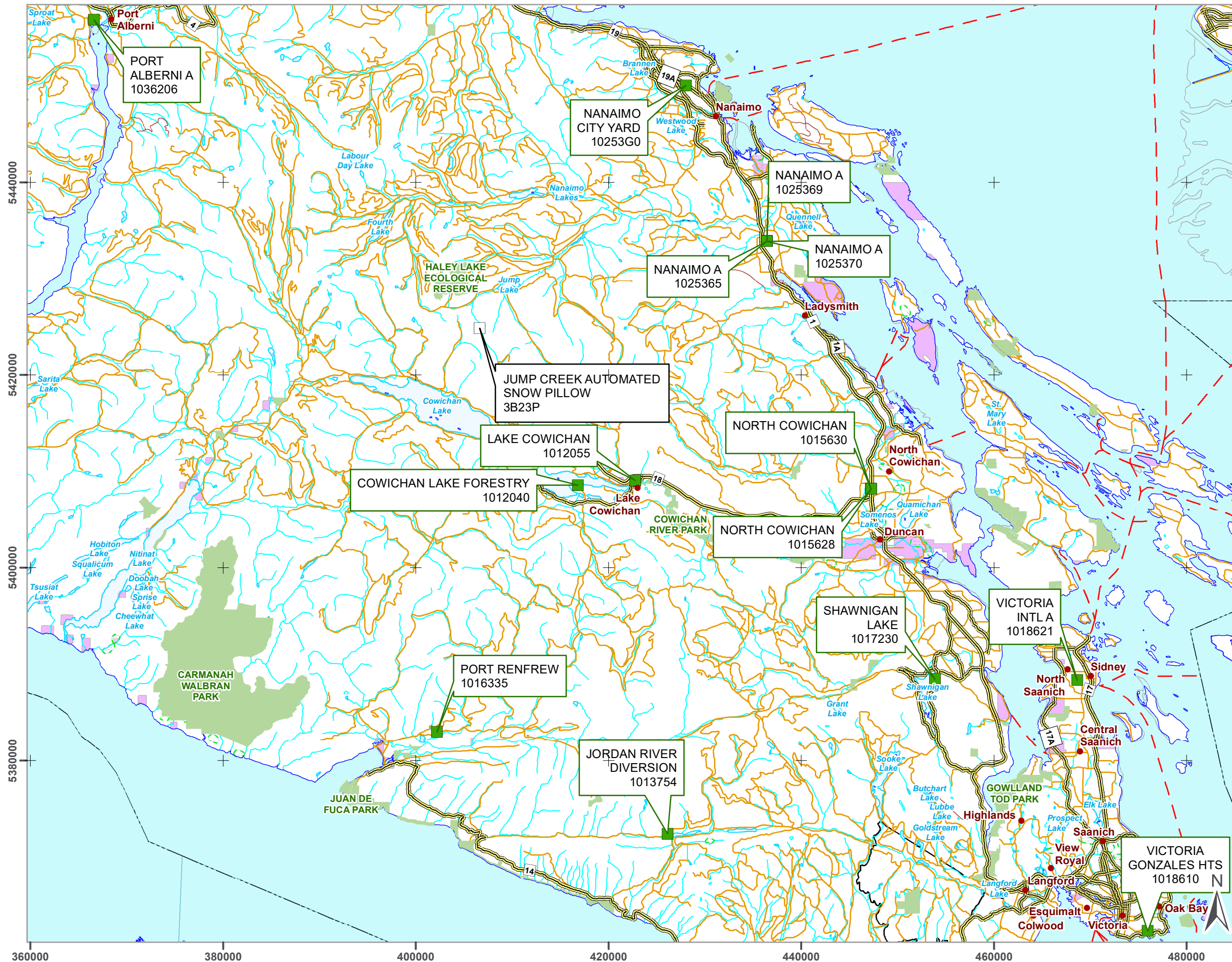

DAM SAFETY REVIEW AND RISK ASSESSMENT OF YOUNG CREEK DAM YOUNG, BC

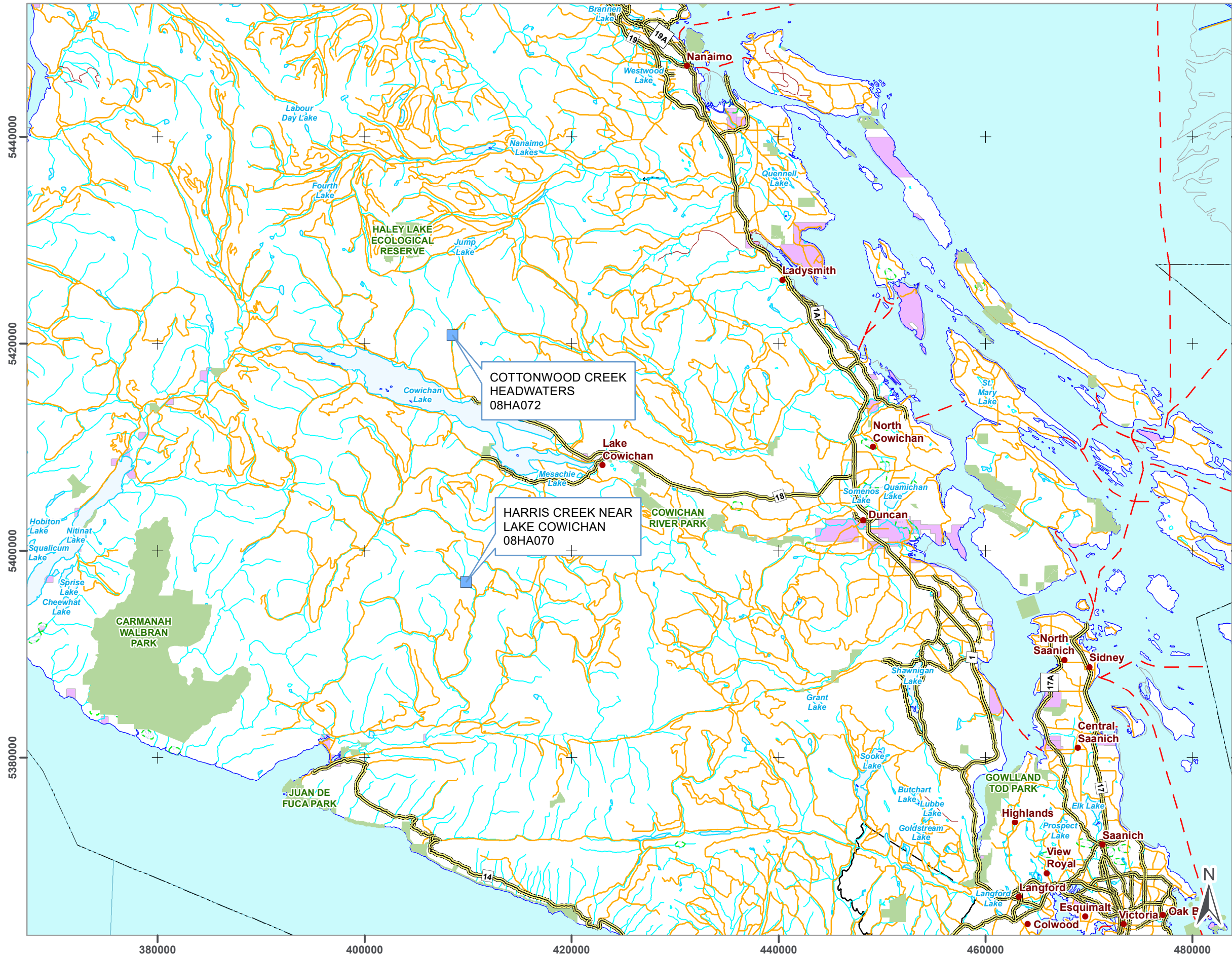

Legend

- Cities
- Hydrometric Station (Water Survey of Canada)
- Highways
- Streams
- Ferry Route
- Roads
- Trail
- Bridge
- Reserves
- Parks



1:370,000

Project No.: GK-18-020-CVD Date: 2018/11/02
 Client: Cowichan Valley Regional District Drawn: MT Check: AG
 NAD 1983 UTM Zone 10N

Figure 9.3

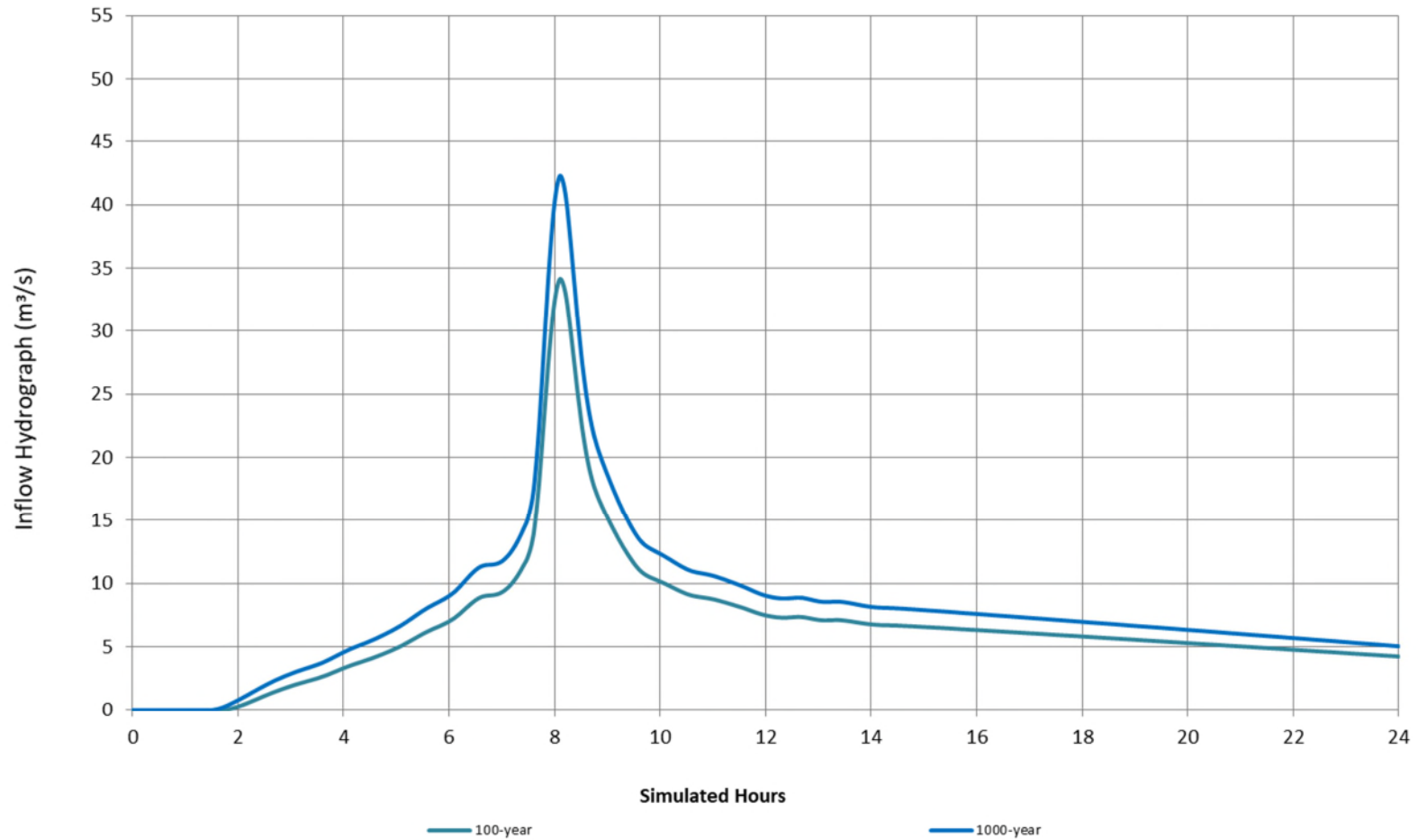

Notes:

DAM SAFETY REVIEW AND RISK ASSESSMENT OF YOUBOU CREEK DAM

Inflow Design Flood Hydrographs

Project No. GK-18-020-CVD
 Client: Cowichan Valley Regional District
 Office: Kelowna
 Scale: NTS
 Date: OCT 31, 2018
 DWN: AG CHK: MJL



Figure 9.4

Storage Capacity and Area Curves Youbou Creek Dam

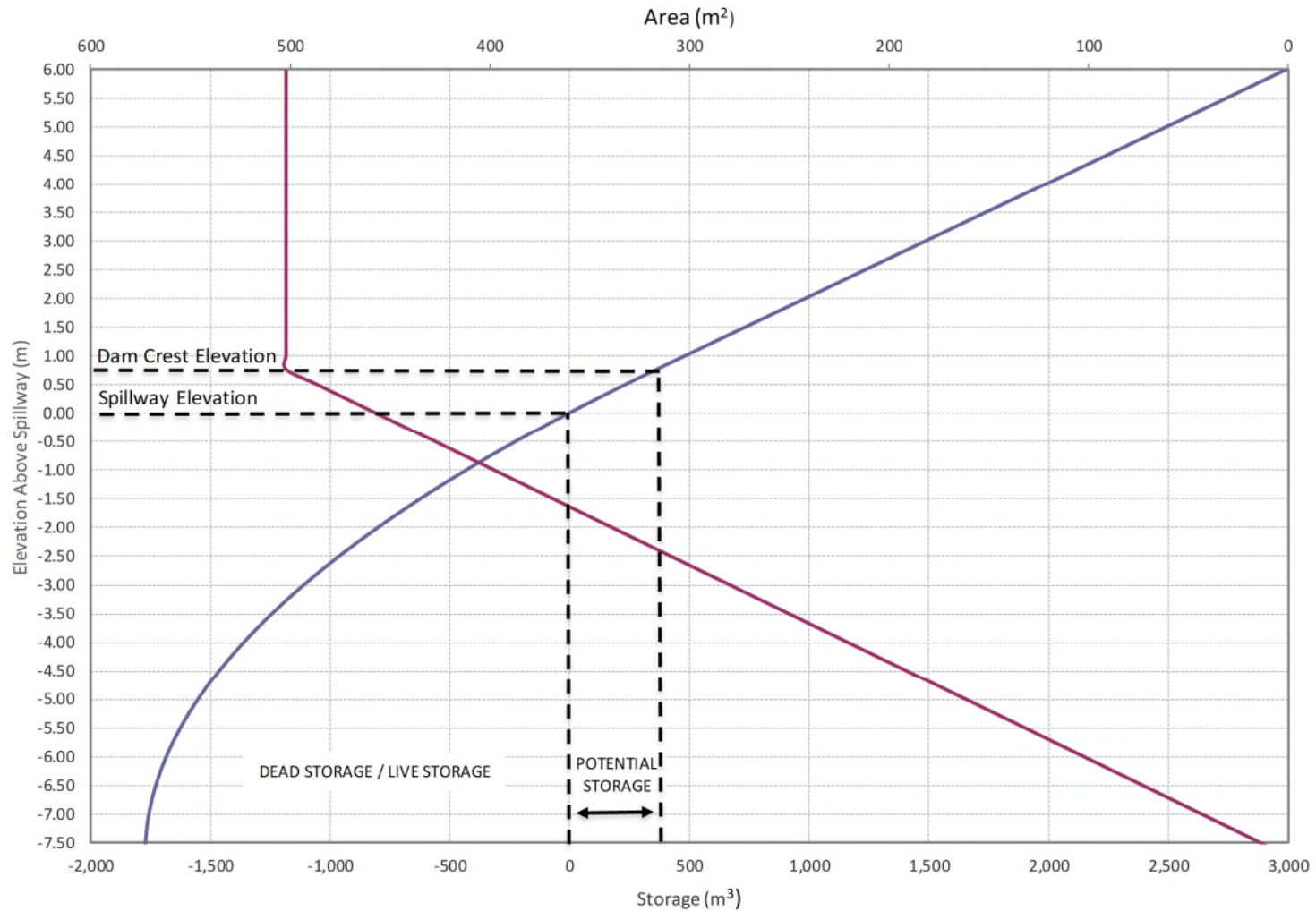

Notes:

Elevation is in reference to Local Datum at Spillway.

DAM SAFETY REVIEW AND RISK ASSESSMENT OF YOUBOU CREEK DAM

Youbou Creek Dam Area Elevation Storage Curves

Project No. GK-18-020-CVD
 Client: Cowichan Valley Regional District
 Office: Kelowna
 Scale: NTS
 Date: OCT 31, 2018
 DWN: AG CHK: MJL



Figure 9.5a

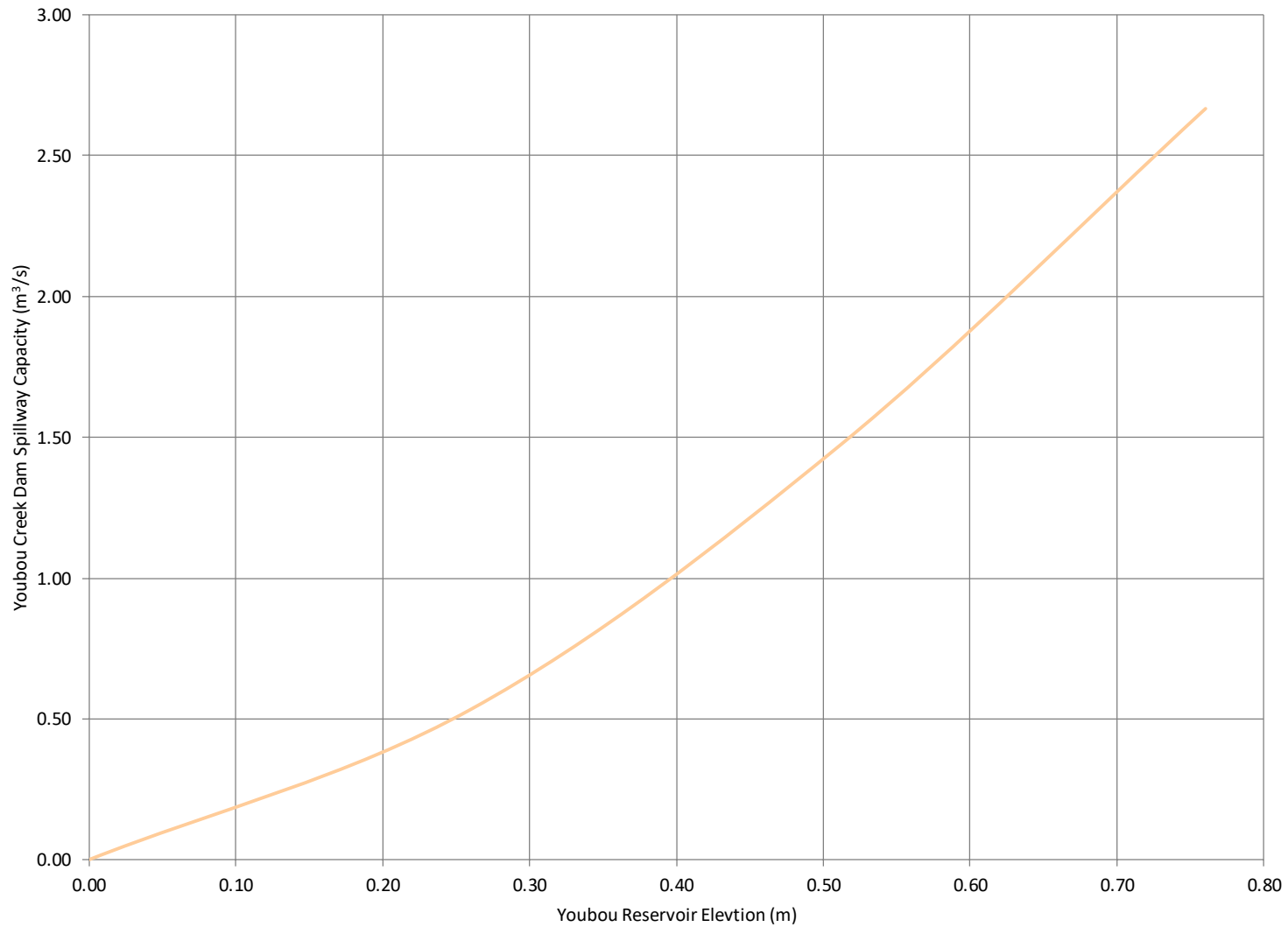

Notes:

Elevation is in reference to Local Datum at Spillway.

**DAM SAFETY REVIEW AND RISK ASSESSMENT
OF YOBOU CREEK DAM**

Youbou Creek Dam Spillway Rating Curve

Project No. GK-18-020-CVD
 Client: Cowichan Valley Regional District
 Office: Kelowna
 Scale: NTS
 Date: OCT 31, 2018
 DWN: AG CHK: MJL



Figure 9.5b

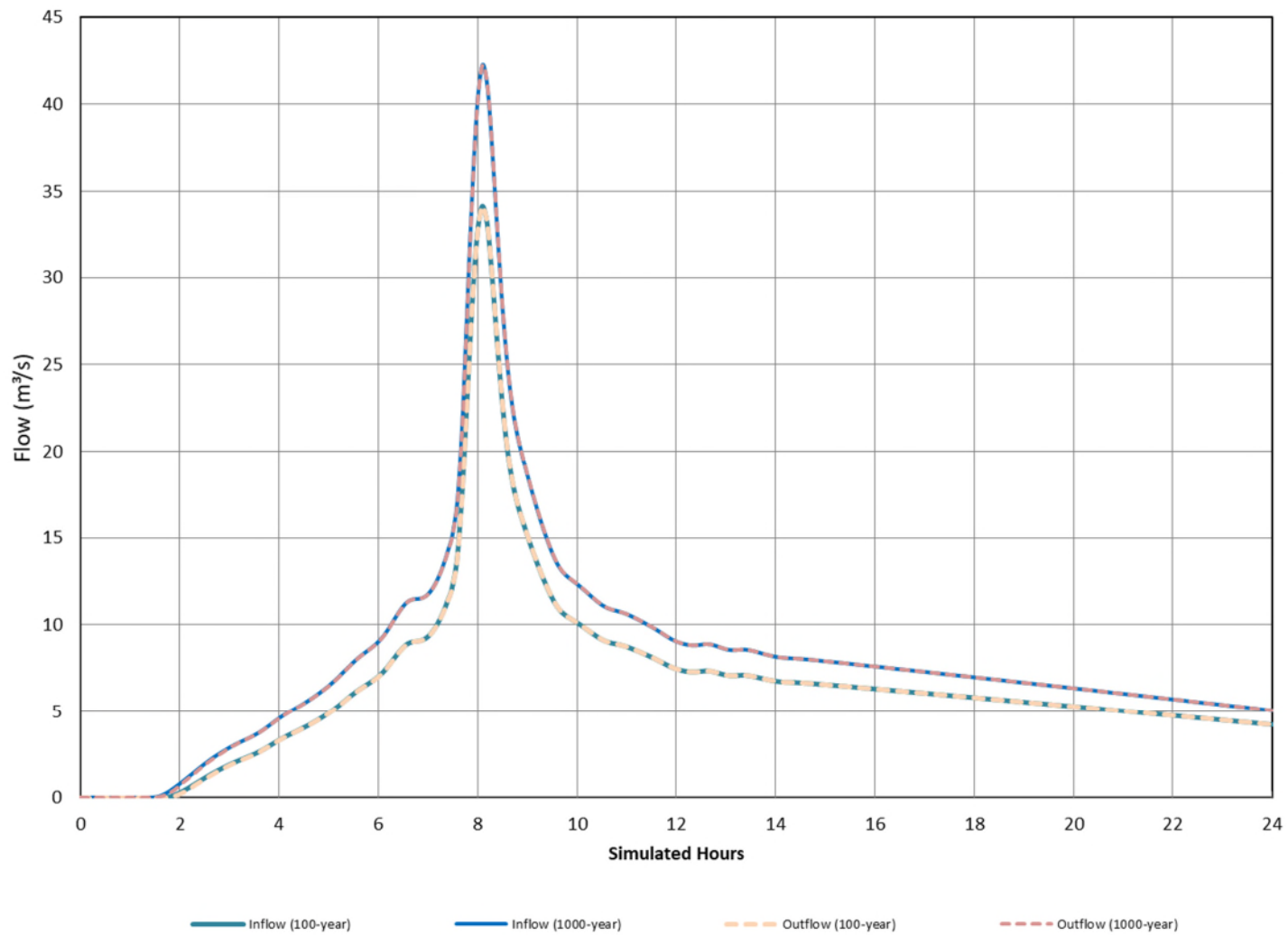

Notes:

DAM SAFETY REVIEW AND RISK ASSESSMENT OF YOUBOU CREEK DAM

Youbou Creek Dam Flood Routing Hydrographs

Project No. GK-18-020-CVD
 Client: Cowichan Valley Regional District
 Office: Kelowna
 Scale: NTS
 Date: OCT 31, 2018
 DWN: AG CHK: MJL



Figure 9.5c

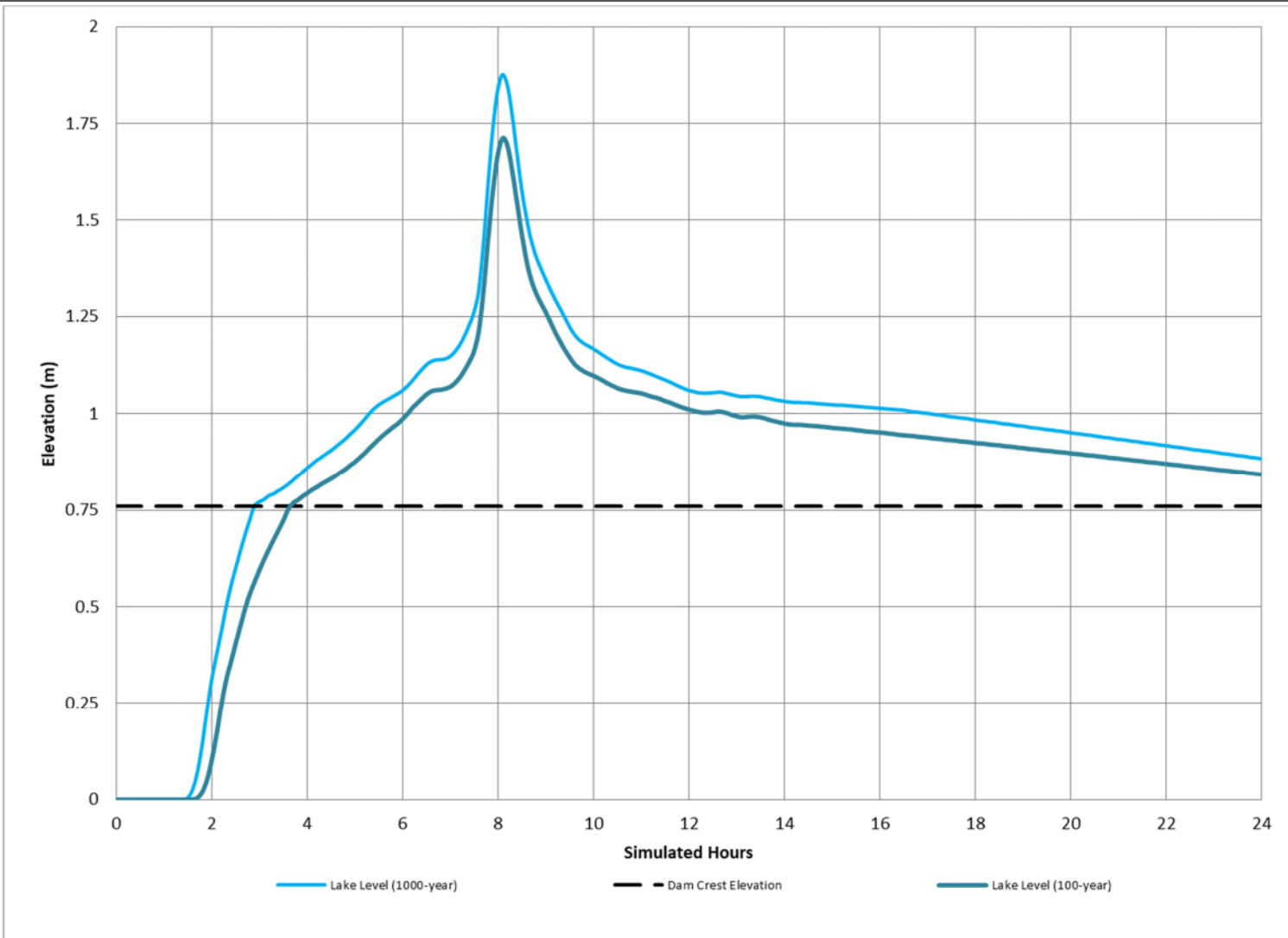

Notes:

Elevation is in reference to Local Datum at Spillway.

DAM SAFETY REVIEW AND RISK ASSESSMENT OF YOUBOU CREEK DAM

Youbou Creek Dam Reservoir Flood Levels

Project No. GK-18-020-CVD
 Client: Cowichan Valley Regional District
 Office: Kelowna
 Scale: NTS
 Date: OCT 31, 2018
 DWN: AG CHK: MJL

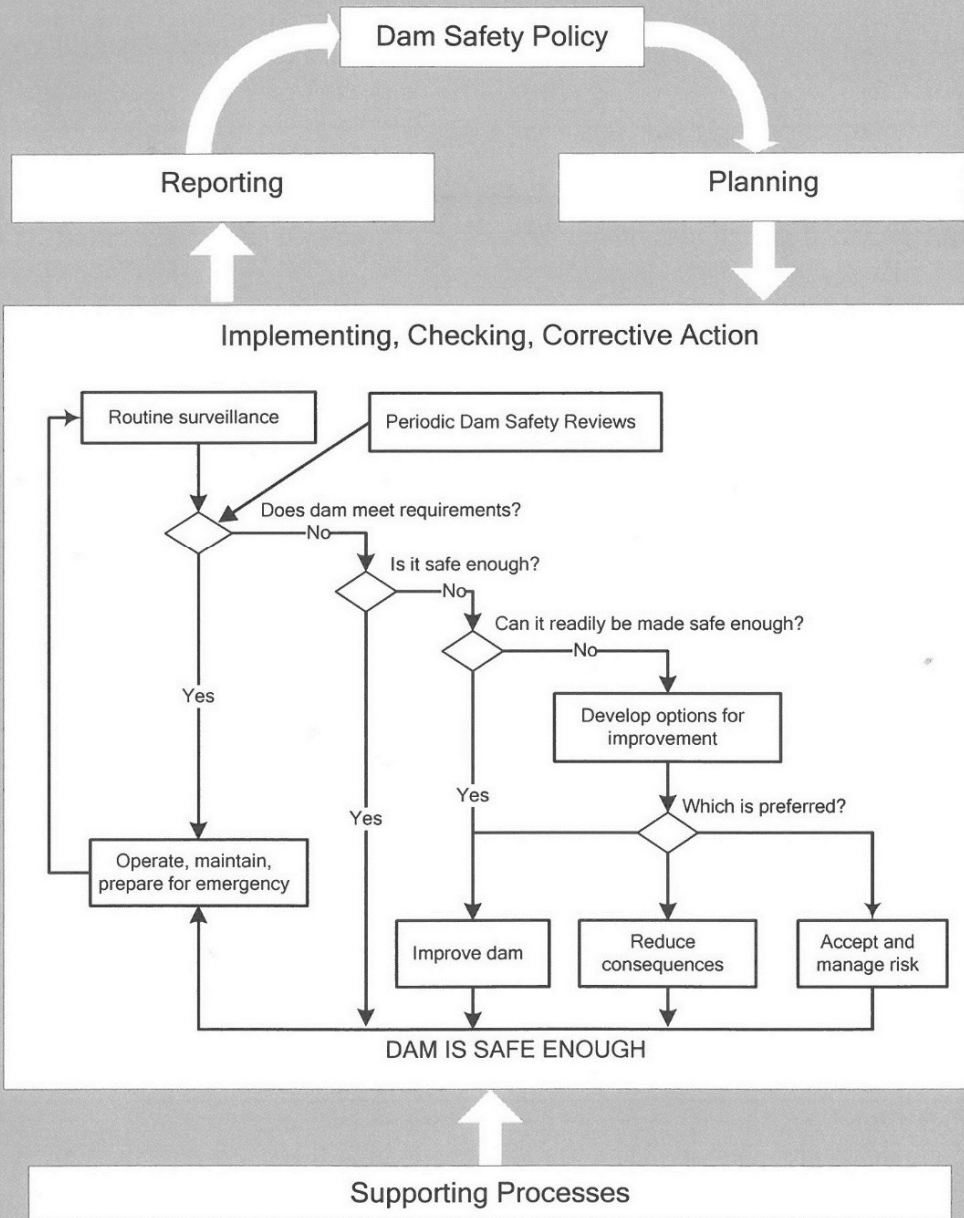

Figure 9.5d

PUBLIC POLICY

DAM OWNER'S POLICIES AND PRIORITIES

DAM SAFETY MANAGEMENT SYSTEM



Notes:

Adapted from Figure 1-1 of Canadian Dam Association Dam Safety Guidelines 2007 (2013 Edition).

DAM SAFETY REVIEW AND RISK ASSESSMENT OF YOUBOU CREEK DAM

Dam Safety Management System

Project No. GK-18-020-CVD
Client: Cowichan Valley Regional District
Office: Kelowna
Scale: NTS
Date: September 19, 2018
DWN: CE CHK: MJL



Figure 10.1

Photographs

Photo 1	Upstream stilling basin and channel leading to culvert.
Photo 2	Reservoir as seen from the upstream side of the dam.
Photo 3	Culvert discharging into reservoir upstream of the dam.
Photo 4	Right upstream access to the dam crest.
Photo 5	Dam crest as viewed from right side of the dam.
Photo 6	Upstream face of the dam above the waterline.
Photo 7	Corroded bent guardrail on the dam crest.
Photo 8	Weathering of concrete on the left side of the spillway at the stoplog insert.
Photo 9	Concrete deterioration at edge of spillway.
Photo 10	Concrete deterioration above and below water line.
Photo 11	Backside of cold joint as viewed from within the reservoir.
Photo 12	Downstream face of the dam as viewed from above at the right abutment.
Photo 13	Downstream face of the dam as viewed from below looking towards right abutment.
Photo 14	Horizontal cracking and erosion on downstream dam face approximately 1 m below the crest.
Photo 15	Vegetation growing on the dam face to the right of the spillway.
Photo 16	Water flowing over spillway as viewed from below.
Photo 17	Downstream face of the dam as viewed from downstream.
Photo 18	Horizontal groove on the left downstream face approximately 1.7 m below the crest.
Photo 19	Weathering on the downstream face noted throughout the crest and front face.
Photo 20	Downstream face as viewed from the left of the spillway.
Photo 21	Low level outlet on the right side of the dam.
Photo 22	Low level outlet pipe and water intake line at left side of the dam.
Photo 23	Low level outlet and water intake pipes viewed from dam crest.
Photo 24	Outlet channel as viewed from the dam crest.



Photo 1 Upstream stilling basin and channel leading to culvert.



Photo 2 Reservoir as seen from the upstream side of the dam.



Photo 3 Culvert discharging into reservoir upstream of the dam.



Photo 4 Right upstream access to the dam crest.



Photo 5 Dam crest as viewed from right side of the dam.



Photo 6 Upstream face of the dam above waterline.



Photo 7 Corroded bent guardrail on the dam crest.



Photo 8 Weathering of concrete on the left side of the spillway at the stoplog insert.



Photo 9 Concrete deterioration at edge of spillway.

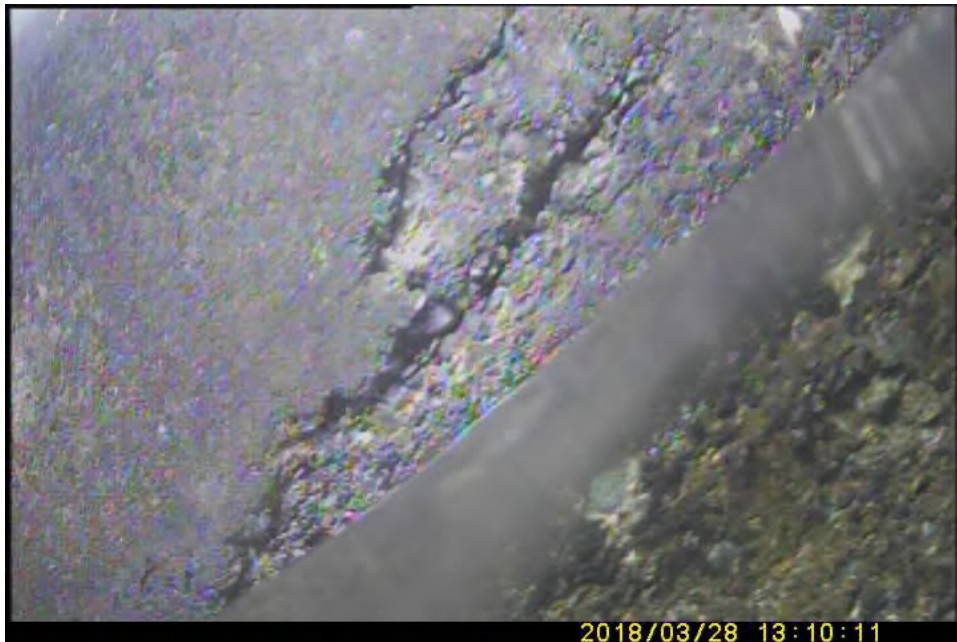

Photo 10 Concrete deterioration above and below water line.



Photo 11 Backside of cold joint as viewed from within the reservoir.



Photo 12 Downstream face of the dam as viewed from above at the right abutment.



Photo 13 Downstream face of the dam as viewed from below looking towards right abutment.



Photo 14 Horizontal cracking and erosion on downstream dam face approximately 1 m below the crest.



Photo 15 Vegetation growing on the dam face to the right of the spillway.



Photo 16 Water flowing over spillway as viewed from below.



Photo 17 Downstream face of the dam as viewed from downstream.



Photo 18 Horizontal groove on the left downstream face approximately 1.7 m below the crest.



Photo 19 Weathering on the downstream face noted throughout the crest and front face.



Photo 20 Downstream face as viewed from the left of the spillway.



Photo 21 Low level outlet on the right side of the dam.



Photo 22 Low level outlet pipe and water intake line at left side of the dam.



Photo 23 Low level outlet and water intake pipes viewed from dam crest.



Photo 24 Outlet channel as viewed from the dam crest.

Appendix A

Background Information Reviewed

Background Review

- March 1991 – Sketch for Repairs to Dam, WO#4125 – Unknown
- January 2006 – Plan of Statutory Right of Way – McElhanney Associates
- January 2006 – Youbou Water Project – Dam Site – Richard Mortimer
- September 2007 – Integration of Youbou Water Systems Reservoir Details – John Braybrooks Engineering

Appendix B

Existing Dam Drawings

YOUBOU CREEK

PORTABLE INLET (PLASTIC)

W.O. # 4125

REPAIRS TO DAM

MARCH 1991

PIPEFITTERS WORK

MILLWRIGHTS WORK

STILLING BASIN

④ DREDGE THE BASIN & REPLACE SMALL DAM (BY CONTRACTOR)

⑤ REPAIR & REHANG THIS 4" PIPE

EXIST. CULVERT

INTO DAM BASIN

(DAM BASIN TO BE DREDGED BY CONTRACTOR)

ROADWAY

① MAKE SURE SPILLWAY BOARDS ARE USABLE WHEN READY

DAM

② REPAIR STUPE

③ REPLACE BOARDS

⑥ BLIND FLANGE

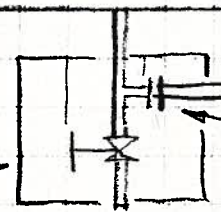

TO TOWNSITE

PLAN OF STATUTORY RIGHT OF WAY OVER PART OF BLOCK 136, COMCHAN LAKE DISTRICT EXCEPT PART CONTAINING 2.34 ACRES MORE OR LESS SHOWN COLOURED RED ON PLAN MARKED 'F' (DD 40883-1), AND EXCEPT PARTS IN PLANS 20033, 21269, 37531 AND VIP60609. (PURSUANT TO SECTION 113, LAND TITLE ACT).

PLAN VIP 80277

DEPOSITED IN THE LAND TITLE OFFICE AT VICTORIA, B.C. THIS 17 DAY OF JAN 2006.

M. Brantley
DEPUTY REGISTRAR

B.C.G.S. 92C.089

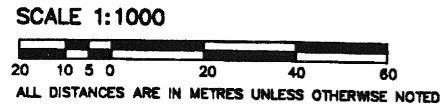

- LEGEND**
- BEARINGS ARE ASTRONOMIC AND DERIVED FROM PLAN 20033
- DENOTES STANDARD IRON POST FOUND
 - DENOTES STANDARD IRON POST SET
 - ⊙ DENOTES NON STANDARD IRON POST FOUND

BOOK OF REFERENCE		
PARCEL DESCRIPTION	PID	AREA
BLOCK 136, COMCHAN LAKE DISTRICT, EXCEPT PART CONTAINING 2.34 ACRES MORE OR LESS SHOWN COLOURED RED ON PLAN MARKED 'F' (DD 40883-1), AND EXCEPT PARTS IN PLANS 20033, 21269, 37531 AND VIP60609.	008-731-954	PT. AREA = 0.831 HA, PT. AREA = 904.7 M ²
		TOTAL AREA = 0.921 HA.

FAB110
aa

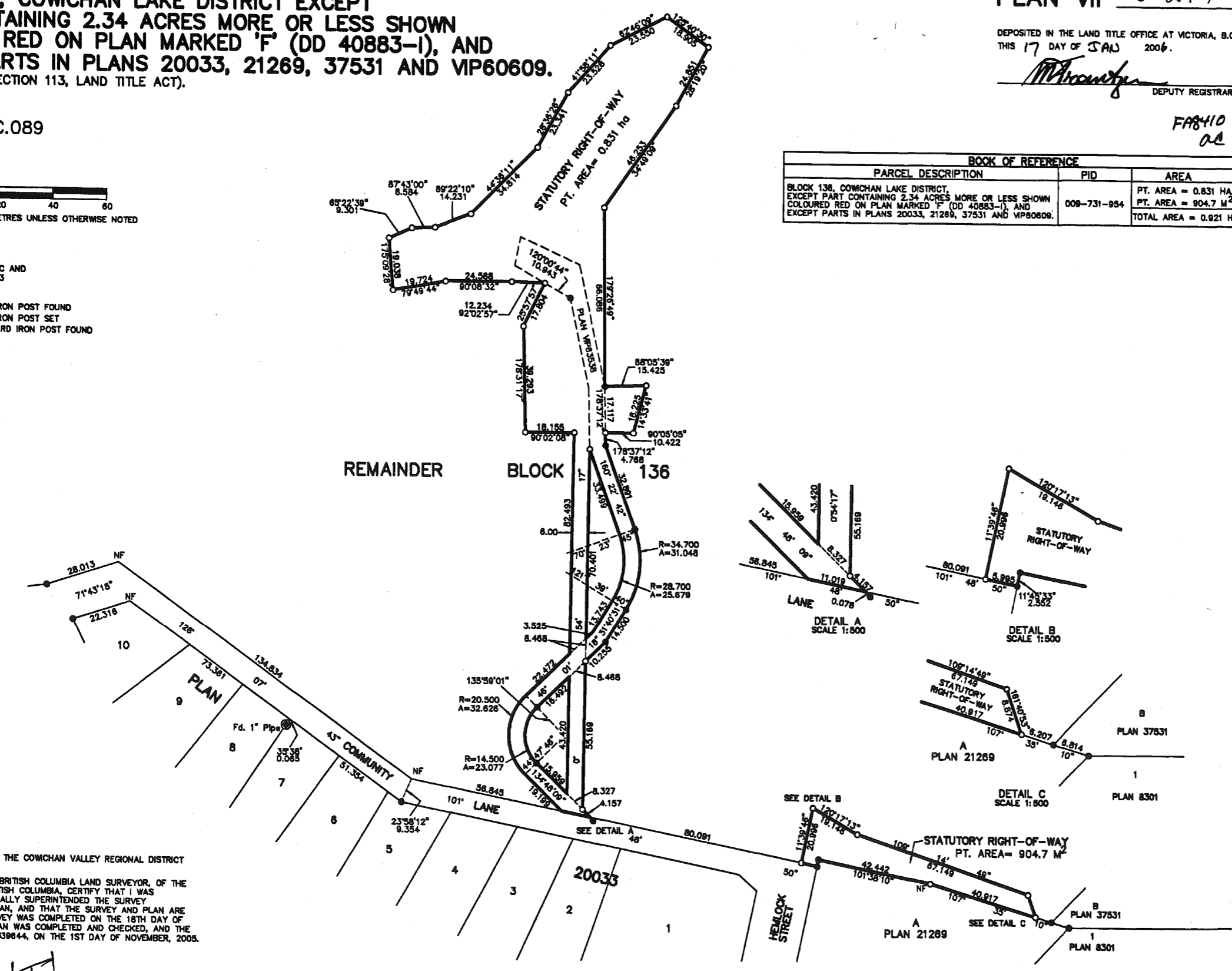

THIS PLAN LIES WITHIN THE COMCHAN VALLEY REGIONAL DISTRICT

I, MICHAEL J. TAYLOR, A BRITISH COLUMBIA LAND SURVEYOR, OF THE CITY OF NANAIMO, IN BRITISH COLUMBIA, CERTIFY THAT I WAS PRESENT AT AND PERSONALLY SUPERINTENDED THE SURVEY REPRESENTED BY THIS PLAN, AND THAT THE SURVEY AND PLAN ARE CORRECT. THE FIELD SURVEY WAS COMPLETED ON THE 18TH DAY OF OCTOBER, 2005. THE PLAN WAS COMPLETED AND CHECKED, AND THE CHECKLIST FILED UNDER #39644, ON THE 1ST DAY OF NOVEMBER, 2005.

Michael J. Taylor
B.C.L.S., C.L.S.

McELHANNEY ASSOCIATES
PROFESSIONAL LAND SURVEYORS
SUITE 1 - 1351 ESTEVAN ROAD
NANAIMO, B.C. V9S 3Y3
OUR FILE: 2232-70008-1

ORIGINAL

Appendix C

Dam Inspection Notes

Table C Site Inspection Observations of the Youbou Creek Dam

General Description of Dam			
Date:	March 28, 2018	Attendees:	Michael J. Laws, P.Eng. (Ecora), Caleb Pomeroy, P.Eng. (Ecora), Dr. Adrian Chantler, P.Eng. (Ecora), Bram Hobuti, P.Eng. (Ecora), David Parker (CVRD)
Weather:	Cloudy	Location:	Cowichan Valley Regional District
Length:	18.3 m	Outlet type:	400 mm Steel Pipe
Max. Height:	8.79 m	Sluice gate:	Gate Valve
Crest Elevation:	N/A	Spillway:	2.38 m long, 0.76 m deep, located at centre
Crest Width:	0.46 m	Spillway Crest Elevation:	N/A
Water Level:	Just above spillway	Downstream Slope Angle:	15°
Appurtenances:	Spillway	Upstream Slope Angle:	Vertical
Observations			
Location			
Foundation	Dam formed on bedrock		
Spillway	Concrete weathering observed around spillway behind steel stoplog insert side plate		
Outlet	300 mm diameter steel low level outlet to the right of spillway, second outlet to the left of the spillway		
Outlet	150 mm diameter steel water supply line to the left of the spillway		
Crest	Wall width measured to be 0.46 m wide		
Crest	Guard railing on dam crest is bent and rusted		
Reservoir	Sediment in reservoir measured to be 1.27 m below crest at right abutment, 3.80 m 2.3 m away from left abutment, 4.35 m 4.9 m away from abutment and 4.7 m at spillway		
Dam Face	Face is angled 15° from vertical with a length measured to be 8.79 m		
Dam Face	Control joints located 1.00 m and 2.84 m down from dam crest		
Dam Face	Seepage was observed to the left of the spillway, vegetation observed growing near seepage area. Dam covered in moss. Face is weathered		
Inlet Channel	Two CSP culverts located above reservoir, measured at 1.2 m and 1.1 m in diameter		
Outlet Channel	Three 1.1 m diameter CSP culverts approximately 6 m long under access road to the dam		

Appendix D

Hazard and Failure Modes Analysis

Table F: Hazards and Failure Modes Analysis (HFMM)

Global Failure Modes	Element And/Or Element Function	Most Basic Functional Failure Characteristics	External Hazards				Internal Hazards (Design, Construction, Maintenance, Operation)				
			Meteorological	Seismic	Reservoir Environment	Human and/or Animal Activities	Water barrier	Hydraulic Structure.	Mechanical/Electrical	Infrastructure & Plans	
DAM COLLAPSE BY OVERTOPPING (erosion or overturning)	Inadequate installed discharge capacity	Meteorological inflow > buffer + outflow capacity	Could a meteorological event cause the inflow to be greater than the buffer capacity and lead to dam overtopping/failure due to insufficient installed discharge capacity?	Could a seismic event cause a meteorological event and cause the dam to be overtopped/fail from a reduced discharge capacity (channels, chutes)?	Could the reservoir environment (landslide? debris?) cause a meteorological event leading to the dam to be overtopped/fail because of insufficient installed discharge capacity?	Could human and/or animal activities cause a meteorological event that leads to the dam being overtopped/fail due to insufficient installed discharge capacity?	Could design or construction of the water barrier cause a meteorological event leading to dam overtopping / failure due to insufficient installed discharge capacity?	Could design or construction of the hydraulic structure cause a meteorological inflow greater than the buffer + outflow capacity and cause the dam to be overtopped/fail?	Could the design or construction of the mechanical/electrical systems cause a meteorological inflow greater than the buffer + outflow capacity and lead to the dam being overtopped/fail due to insufficient installed discharge capacity?	Could inadequate infrastructure and plans cause a meteorological inflow greater than the buffer + outflow capacity and lead to the dam being overtopped/fail due to insufficient installed discharge capacity?	
		Inadequate reservoir operation (rules not followed)	Could the dam be overtopped/fail during a meteorological event if the operating rules are not followed?	Could a seismic event create a condition that prevents the operating rules from being followed, leading to the dam being overtopped/fail?	Could the reservoir environment cause the operating rules to not be followed leading to the dam being overtopped/fail?	Could human and/or animal activities cause the operating rules to not be followed leading to the dam being overtopped/fail?	Could design or construction of the water barrier cause the operating rules to not be followed and cause the dam to be overtopped/fail?	Could the design or construction of the hydraulic structure cause the operating rules to not be followed and lead to dam collapse by overtopping?	Could the design or construction of the mechanical/electrical systems cause the operating rules to not be followed leading to dam overtopping/failure?	Could inadequate infrastructure and plans cause inadequate reservoir operation leading to dam collapse by overtopping?	
	Inadequate available discharge capacity	Random functional failure on demand	Could the dam be overtopped/fail during a meteorological event if there is a random functional failure of spillway capability?	Could a seismic event cause a random functional failure of spillway capability leading to the dam to be overtopped/fail?	Could the reservoir environment cause random functional failure or damaged or damaged spillway capability and lead to the dam being overtopped/fail?	Could human and/or animal activities cause random functional failure or spillway capability causing the dam to be overtopped/fail?	Could design or construction of the water barrier cause a random functional failure of spillway capability and cause the dam to be overtopped/fail?	Could the design or construction of the hydraulic structure cause random functional failure of spillway capability and lead to the dam being overtopped/fail due to inadequate available discharge capacity?	Could the design or construction of the mechanical/electrical systems cause a random functional failure on demand leading to dam overtopping?	Could inadequate infrastructure and plans cause random functional failure on demand leading to dam collapse by overtopping?	
		Discharge capability not maintained or retained	Could the dam be overtopped/fail during a meteorological event if the discharge capacity is not maintained?	Could a seismic event cause the discharge capacity to be damaged causing the dam to be overtopped/fail?	Could the reservoir environment cause loss of the discharge capacity leading to the dam being overtopped/fail?	Could human and/or animal activities cause loss of discharge capacity and cause the dam to be overtopped/fail?	Could design or construction of the water barrier cause the discharge capacity to be not maintained/retained and cause the dam to be overtopped/fail?	Could the design or construction of the hydraulic structure cause loss of the discharge capacity and lead to the dam being overtopped/fail due to inadequate available discharge capacity?	Could the design or construction of the mechanical/electrical systems cause the discharge capacity to be not maintained / retained leading to dam collapse by overtopping?	Could inadequate infrastructure and plans cause discharge capacity to not be maintained or retained leading to dam collapse by overtopping?	
	Inadequate freeboard	Excessive elevation due to landslide or U/S dam	Could the dam be overtopped/fail during a meteorological event due to a reservoir landslide or upstream dam failure?	Could a seismic event cause the dam to be overtopped/fail due to a reservoir landslide or upstream dam failure?	Could the reservoir environment cause excessive elevation of the reservoir leading to the dam being overtopped/fail?	Could human and/or animal activities cause a landslide or upstream dam failure leading to the dam being overtopped/fail?	Could design or construction of the water barrier cause a reservoir landslide or upstream dam failure and cause the dam to be overtopped/fail?	Could the design or construction of the hydraulic structure cause excessive elevation due to a landslide or upstream dam failure leading to the dam being overtopped/fail due to inadequate freeboard?	Could the design or construction of the mechanical/electrical systems cause excessive elevation due to landslide or upstream dam failure leading to dam collapse by overtopping?	Could inadequate infrastructure and/or plans cause the dam to fail due to a reservoir landslide or upstream dam failure?	
		Wind-wave dissipation inadequate	Is freeboard and wind wave dissipation adequate to prevent overtopping/failure during a meteorological event?	Could a seismic event cause the dam to be overtopped/fail due to inadequate freeboard and wind wave dissipation?	Is freeboard and wind wave dissipation adequate to prevent overtopping/failure from failure of features in the reservoir environment?	Could human and/or animal activities cause inadequate freeboard and wind wave dissipation leading to dam overtopping/failure?	Could design or construction of the water barrier cause inadequate freeboard and wind wave dissipation and cause overtopping/failure?	Could the design or construction of the hydraulic structure cause inadequate wind-wave dissipation leading to dam collapse by overtopping?	Could the design or construction of the mechanical/electrical systems cause inadequate wind-wave dissipation leading to dam collapse by overtopping?	Could inadequate infrastructure and plans cause inadequate wind-wave dissipation leading to dam collapse by overtopping?	
	Management System Failure	Safeguards fail to provide timely detection and correction	Operation, maintenance and surveillance fail to detect/prevent hydraulic adequacy	Could a meteorological event prevent the Dam Safety Engineers activities (based on OMS requirements, see column L) from detecting/prevent hydraulic adequacy leading to dam overtopping/failure?	Could a seismic event prevent the Dam Safety Engineers activities (based on OMS requirements, see column L) from detecting/prevent hydraulic adequacy leading to overtopping/failure of the dam?	Could the reservoir environment prevent Dam Safety activities (based on OMS requirements, see column L) from detecting/prevent hydraulic adequacy leading to dam overtopping/failure?	Could human and/or animal activities cause the OMS activities to not detect/prevent hydraulic adequacy leading to dam overtopping/failure?	Could inadequate operation, maintenance and surveillance fail to detect / prevent hydraulic adequacy and lead to failure of the water barrier?	Could inadequate operation, maintenance and surveillance fail to detect / prevent hydraulic adequacy and lead to failure of the hydraulic structure?	Could inadequate operation, maintenance and surveillance fail to detect / prevent failure of the mechanical/electrical system leading to dam collapse by overtopping?	Could inadequate operation, maintenance and surveillance of the infrastructure and plans cause the OMS activities to not detect /prevent hydraulic adequacy before leading to overtopping/failure of dam?
			Operation, maintenance and surveillance fail to detect poor dam performance	Could the meteorological event prevent the OMS rules from being implemented by the DS Engineer leading to dam collapse by loss of strength?	Could a seismic event cause the OMS rules to not be followed leading to collapse by loss of strength during a seismic event?	Could the reservoir environment cause the OMS rules to not be followed leading to dam collapse by loss of strength?	Could human and/or animal activities cause OMS activities to not be followed leading to dam collapse by loss of strength?	Could inadequate operation, maintenance and surveillance fail to prevent poor dam performance and lead to dam collapse by loss of strength?	Could inadequate operation, maintenance and surveillance of the hydraulic structure fail to prevent poor dam performance and lead to dam collapse by loss of strength?	Could inadequate operation, maintenance and surveillance of the mechanical/electrical systems fail to prevent poor dam performance and lead to dam collapse by loss of strength?	Could inadequate surveillance and management of the infrastructure and plans cause the OMS activities to not detect /prevent dam collapse by loss of strength?
	DAM COLLAPSE BY LOSS OF STRENGTH (External or internal structural failure and weakening)	Stability under applied loads	Mass movement (external stability- displacement, tilting, seismic resistance)	Could loss of strength and mass instability occur during a meteorological event and cause dam collapse?	Could a seismic event cause mass external instability and cause dam collapse?	Could the reservoir environment cause external instability of the dam leading to dam collapse?	Could human and/or animal activities cause external instability of the dam and cause dam collapse?	Could design or construction of the water barrier cause external instability and lead to dam collapse?	Could the design or construction of the hydraulic structure cause external instability leading to dam collapse by loss of strength?	Could the design or construction of the mechanical/electrical systems cause external instability leading dam collapse by loss of strength?	Could inadequate infrastructure and plans cause external instability leading to dam collapse by loss of strength?
			Loss of support (foundation or abutment failure)	Could reduction/lack of support in foundation or abutments during a meteorological event cause dam collapse?	Could a seismic event cause reduction/lack of support in foundation or abutments leading to dam collapse?	Could the reservoir environment (debris, ice, landslides) cause foundation or abutment failure leading to dam collapse?	Could human and/or animal activities cause reduction/lack of support in foundation or abutments and cause dam collapse?	Could design or construction of the water barrier cause reduction/lack of support in foundation or abutments and cause dam collapse?	Could the design or construction of the hydraulic structure cause reduction/lack of support in foundation or abutments and lead to dam collapse by loss of strength?	Could the design or construction of the mechanical/electrical systems cause a reduction/lack of support in foundation or abutments leading to dam collapse by loss of strength?	Could inadequate infrastructure and plans cause reduction/lack of support in foundation or abutments leading to dam collapse by loss of strength?
Watertightness		Seepage around interfaces (abutments, foundation, water stops)	Could seepage around interfaces/abutments/foundation during meteorological event reduce watertightness sufficient to cause dam collapse?	Could a seismic event cause seepage around interfaces / abutments / foundation reduce watertightness sufficient to cause dam collapse?	Could the reservoir environment (debris, ice, landslides) cause seepage around interfaces/abutments/foundation and reduce watertightness sufficient to cause dam collapse?	Could human and/or animal activities cause seepage around interfaces / abutments / foundation and reduce watertightness sufficient to cause dam collapse?	Could design or construction of the water barrier cause seepage around interfaces / abutments / foundation and reduce watertightness sufficient to cause dam collapse?	Could the design or construction of the hydraulic structure cause seepage around interfaces/ abutments/ foundation leading to dam collapse by loss of strength?	Could the design or construction of the mechanical/electrical systems cause seepage around interfaces/ abutments/ foundation leading to dam collapse by loss of strength?	Could inadequate infrastructure and plans cause seepage around interfaces/ abutments/ foundation and reduce watertightness sufficient to cause dam collapse by loss of strength?	
		Through dam seepage control failure (filters, drains, pumps)	Could through -dam seepage (filters/drains/pumps, internal instability) during a meteorological event reduce watertightness and cause dam collapse?	Could a seismic event cause through dam seepage (filters/drains/pumps) to fail and reduce watertightness and cause dam collapse?	Could the reservoir environment (landslides, ice, debris) cause through dam seepage control be lost (filters/drains/pumps) and reduce watertightness and cause dam collapse?	Could human and/or animal activities cause failure of through dam seepage (filters / drains / pumps) control and reduce watertightness and cause dam collapse?	Could design or construction of the water barrier cause through dam seepage (filters / drains / pumps) and reduce watertightness and cause dam collapse?	Could the design or construction of the hydraulic structure cause through dam seepage control failure (filters/ drains/ pumps) and lead to dam collapse by loss of strength?	Could the design or construction of the mechanical/electrical systems cause through dam seepage (filters/ drains/ pumps) and reduce watertightness and cause dam collapse?	Could inadequate infrastructure and plans cause through dam seepage (filters/ drains/ pumps) and cause dam collapse by loss of strength?	
Durability/cracking		Structural weakening (internal erosion, AAR, crushing, gradual strength loss)	Could structural weakening, internal erosion, crushing, cracking, strength loss caused by a meteorological event cause dam collapse?	Could a seismic event cause internal structural weakening (internal erosion, crushing, cracking, strength loss) and cause dam collapse?	Could the reservoir environment (landslides, ice, debris) cause internal structural weakening (internal erosion, crushing, cracking, strength loss) and lead to dam collapse?	Could human and/or animal activities cause internal structural weakening (internal erosion, crushing, cracking, strength loss) and cause dam collapse?	Could design or construction of the water barrier cause internal structural weakening (internal erosion, crushing, cracking, strength loss) and cause dam collapse?	Could the design or construction of the hydraulic structure cause internal structural weakening (internal erosion, crushing, cracking, strength loss) leading to dam collapse?	Could the design or construction of the mechanical/electrical systems cause internal structural weakening (internal erosion, crushing, cracking, strength loss) leading to dam collapse by loss of strength?	Could inadequate infrastructure and plans cause internal structural weakening (internal erosion, crushing, cracking, strength loss) and cause dam collapse by loss of strength?	
		Instantaneous change of state (static liquefaction, hydraulic fracture, seismic cracking)	Could instantaneous change of state occur (Liquefaction, hydraulic fracture) caused by a meteorological event cause dam collapse?	Could a seismic event cause instantaneous change of state to occur (Liquefaction, hydraulic fracture) leading to dam collapse?	Could the reservoir environment (landslides, ice, debris) cause instantaneous change of state to occur (liquefaction, hydraulic fracture) and cause dam collapse?	Could human and/or animal activities cause instantaneous change of state to occur (Liquefaction, hydraulic fracture) and cause dam collapse?	Could design or construction of the water barrier cause instantaneous change of state occur (Liquefaction, hydraulic fracture) and cause dam collapse?	Could the design or construction of the hydraulic structure cause instantaneous change of state to occur (Liquefaction, hydraulic fracture) leading to dam collapse?	Could the design or construction of the mechanical/electrical systems cause instantaneous change of state to occur (Liquefaction, hydraulic fracture) leading to dam collapse by loss of strength?	Could inadequate infrastructure and plans cause instantaneous change of state occur (Liquefaction, hydraulic fracture) and cause dam collapse by loss of strength?	

Appendix E

Dam Stability and Foundation Calculations

Youbou Dam Stability Review

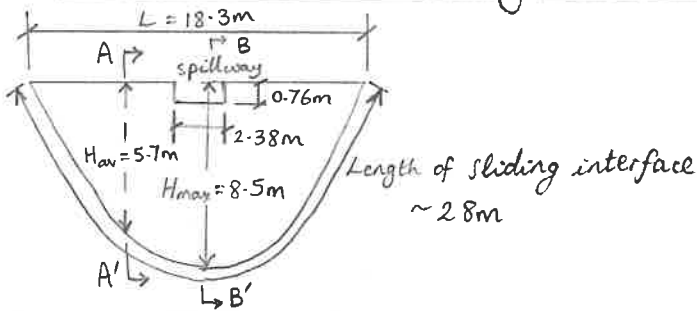

Assume:

- $\gamma_w = 9.81 \text{ kN/m}^3$ (unit weight water)
- $\gamma_c = 24 \text{ kN/m}^3$ (unit weight concrete)
- $\gamma'_s = 8 \text{ kN/m}^3$ (effective unit weight of silt).

Find Average Sliding Resistance - per m length of dam

- Find average weight per m length of dam crest, L
- Find area of sliding interface per m length of dam crest, L

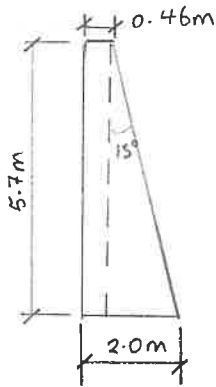

SECTION A-A'
(average cross-section)

Weight of average cross-section, $W =$

$$W = 24 \times (5.7 \times 0.46 + \frac{1}{2} \times 1.5 \times 5.7) = 165.5 \text{ kN/m}$$

Area of sliding interface, $A_s =$

$$A_s = 28 \times 2 = 56 \text{ m}^2, \quad \frac{A_s}{L} = \frac{56}{18.3} = 3.06 \text{ m}^2/\text{m}$$

Average Sliding Resistance, $R_{SL} =$

$$R_{SL} = (W + P_a \sin \delta) \tan \phi \times \frac{A_s}{L}$$

$\tan \phi = 0.7$ (Table 24.4, CFEM, concrete-to-sound rock interface factor)

$$R_{SL} = [165.5 + \frac{1}{2} \times 0.45 \times 8 \times (5.7 - 3.8)^2 \times \sin(18^\circ)] \times 0.7 \times 3.06 = 358.9 \text{ kN/m}$$

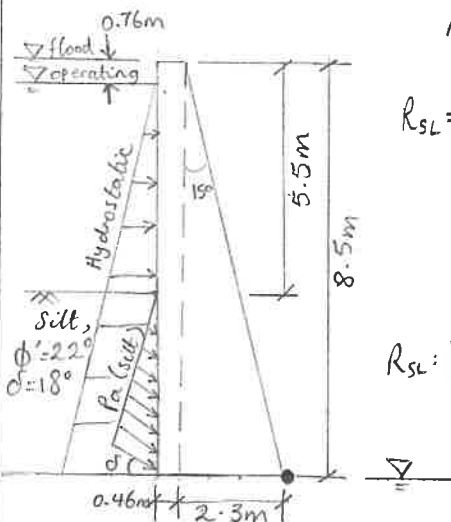
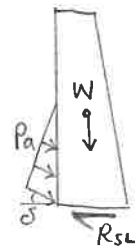

SECTION B-B'
(max height)

$$D_{SL} = \begin{matrix} \text{Hydrostatic} \\ \gamma_w H_w \end{matrix} + \begin{matrix} \text{Silt} \\ \gamma_s H_s \end{matrix}, \text{ Disturbing force}$$

OPERATIONAL - Case 1: Dead + operating hydrostatic + Silt

$$D_{SL} = \frac{1}{2} \gamma_w H_w^2 + \frac{1}{2} K_a \gamma'_s H_s^2, \text{ assume water is at spillway elevation.}$$

$$D_{SL} = \frac{1}{2} \times 9.81 \times (8.5 - 0.76)^2 + \frac{1}{2} \times 0.45 \times 18 \times (8.5 - 5.5)^2 \times \cos(18^\circ) = 309.4 \text{ kN/m}$$

$$K_a = \frac{1 - \sin(22)}{1 + \sin(22)} = 0.45$$

$$F_{S_{SL}} = \frac{R_{SL}}{D_{SL}} = \frac{358.9}{309.4} = 1.2 < 1.5 - \text{does not meet CDA criteria}$$

• **OVERTURNING**, $FS_o = \frac{R_o}{D_o}$ about D/S toe of dam

$$R_o = \left[\begin{array}{c} \downarrow \\ W_1 \end{array} \right] \times (1.5 + \frac{1}{2} \times 0.46) + \left[\begin{array}{c} \downarrow \\ W_2 \end{array} \right] \times (\frac{2}{3} \times 1.5) + P_a \sin \delta \times 2$$

$$R_o = 24 \times 5.7 \times 0.46 \times (2.3 + \frac{1}{2} \times 0.46) + 24 \times \frac{1}{2} \times 5.7 \times 1.5 \times (\frac{2}{3} \times 2.3) + 2.03 \times 2 = 320.6 \text{ kNm/m}$$

$$D_o = \left[\begin{array}{c} \triangle \\ \end{array} \right] \frac{1}{2} \gamma_w H_w^2 \times \frac{1}{3} \times (8.5 - 0.76) + \left[\begin{array}{c} \triangle \\ \end{array} \right] \frac{1}{2} K_a \gamma'_s H_s^2 \times \cos \delta \times \frac{1}{3} \times (8.5 - 5.5)$$

$$D_o = \frac{1}{2} \times 9.81 \times (8.5 - 0.76)^2 \times \frac{1}{3} + \frac{1}{2} \times 0.45 \times 18 \times (8.5 - 5.5)^2 \times \cos(18^\circ) \times \frac{1}{3} = 773.7 \text{ kNm/m}$$

$$FS_o = \frac{R_o}{D_o} < 1.0 - \text{When neglecting contribution from side shear}$$

Side shear, R_{SL} , assume acting at location of average height.

$$R_o = 320.6 + 358.9 \times (8.5 - 5.7) = 1325.6 \text{ kNm/m}$$

$$FS_o = \frac{1325.6}{773.7} = 1.7 > 1.2 \text{ OK}$$

• **UPLIFTING**: Seepage analysis showed negligible seepage, therefore this case has not been analysed.

FLOOD - Case 2 : Dead + IDF hydrostatic + Silt

→ Assume water is at dam crest

$$D_{SL} = \frac{1}{2} \times 9.81 \times 8.5^2 + \frac{1}{2} \times 0.45 \times 8 \times (8.5 - 5.5)^2 \times \cos(18^\circ) = 370.0 \text{ kN/m}$$

$$FS_{SL} = \frac{358.9}{370.0} \approx 1.0 < 1.1 \text{ - does not meet CDA criteria.}$$

$$D_o = \frac{1}{2} \times 9.81 \times (8.5)^3 / 3 + \frac{1}{2} \times 0.45 \times 8 \times (8.5 - 5.5)^3 \times \cos(18^\circ) \times \frac{1}{3} = 1019.7 \text{ kNm/m}$$

$$FS_o = \frac{1325.6}{1019.7} = 1.3 > 1.1 \quad \checkmark \text{ OK.}$$

EARTHQUAKE - Case 3 : Dead + Operating hydrostatic + Silt + Seismic load

PGA = 0.375 (1/1000 AEP)

$$K_{ae} = \frac{\cos^2(\phi' - \theta - \alpha)}{\cos \theta \cos^2 \alpha \cos(\alpha + \delta + \theta) \left[1 + \sqrt{\frac{\sin(\phi' + \delta) \sin(\phi' - \theta - \alpha)}{\cos(\alpha + \delta + \theta) \cos(i - \alpha)}} \right]^2}$$

$$\phi' = 22^\circ$$

$$\theta = \tan^{-1}(0.375) = 21^\circ$$

$$\delta = 18^\circ$$

$$\alpha = 0^\circ$$

$$i = 0^\circ$$

$$K_{ae} = \frac{\cos^2(22 - 21 - 0)}{\cos(21) \cos^2 0 \cos(0 + 18 + 21) \left[1 + \sqrt{\frac{\sin(22 + 18) \sin(22 - 21 - 0)}{\cos(0 + 18 + 21) \cos(0 - 0)}} \right]^2}$$

$$K_{ae} = 1.1$$

$$D_{SL} = \frac{1}{2} \times 9.81 \times (8.5 - 0.76)^2 + \frac{1}{2} \times 1.1 \times 8 \times (8.5 - 5.5)^2 \cos(18^\circ) = 331.4 \text{ kN/m}$$

$$FS_{SL} = \frac{358.9}{331.4} = 1.1 > 1.0 \quad \checkmark \text{ OK}$$

$$D_o = \frac{1}{2} \times 9.81 \times (8.5 - 0.76)^3 \times \frac{1}{3} + \frac{1}{2} \times 1.1 \times 8 \times (8.5 - 5.5)^3 \times \cos(18^\circ) \times \frac{1}{3} = 795.7 \text{ kNm/m}$$

$$FS_o = \frac{1325.6}{795.7} = 1.7 > 1.0 \quad \checkmark \text{ OK}$$

Project:

Project Number:

Date:

By:

Page: 3

of 5

Checked:

ecora

POST-SEISMIC - Case 4: Dead + Operating hydrostatic + Silt + Uplift.

- Assume a crack has been formed in the foundation and hydrostatic pressure is applied at the base of the concrete dam foundation.

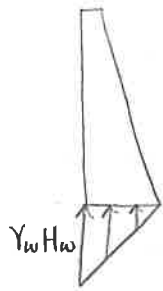

$$R_{SL} = (W + Pa \sin \delta - \gamma_w H_w \cdot B_s^2 \cdot \frac{1}{2}) \tan \delta \times \frac{A_s}{L}$$

$$R_{SL} = \left[165.5 + \left(\frac{1}{2} \times 0.45 \times 8 \times (5.7 - 3.8)^2 \times \sin(18^\circ) - 9.81 \times (5.7 - 0.76) \cdot \frac{2^2}{2} \right) \times 0.7 \times 3.06 \right]$$

$$R_{SL} = 151.3 \text{ kN/m}$$

$$FS_{SL} = \frac{R_{SL}}{D_{SL}} = \frac{151.3}{309.4} = 0.5 \ll 1.1$$

$$D_o = D_o (\text{Case 1}) + \frac{1}{2} \gamma_w H_w B_s^2 \cdot \left(\frac{2}{3} \cdot B_s \right)$$

$$D_o = 773.7 + \frac{1}{2} \times 9.81 \times (8.5 - 0.76) \times (2.3 + 0.46)^2 \times \frac{2}{3} \times (2.3 + 0.46)$$

$$D_o = 1305.8 \text{ kNm/m}$$

$$R_o = 320.6 + 151.3 \times (8.5 - 5.7) = 744.3 \text{ kNm/m}$$

$$FS_o = \frac{R_o}{D_o} = \frac{744.3}{1305.8} = 0.6 \ll 1.1$$

Bearing Capacity Check

Allowable bearing capacity from Table 9.3 CFEM (2006): 3 MPa.

Max. stress applied by gravity wall at dam's max. height:

$$\begin{aligned} W + Pa \sin \delta &= 24(8.5 \times 0.46 + \frac{1}{2} \times 8.5 \times 2.3) + \left(\frac{1}{2} \times 0.45 \times 8 \times (8.5 - 5.5)^2 \sin(18^\circ) \right) \\ &= 333.4 \text{ kN/m} \end{aligned}$$

$$333.4 / (0.46 + 2.3) = 120.8 \text{ kPa} \ll 3 \text{ MPa} \quad \checkmark \text{OK}$$

POSITION OF RESULTANT

$$e = \frac{M}{V}$$

Case 1 : Operational

$$M = D_0 = 773.7 \text{ kNm/m} \quad (\text{page 2})$$

$$V = W + P_a \sin \delta = 333.4 \text{ kN/m} \quad (\text{page 4})$$

$$e = \frac{773.7}{333.4} = 2.32 \text{ m}$$

Percentage of base = $2.32 / (2.3 + 0.46) = \underline{84.1\%}$ - does not meet CDA criteria (outside of middle 1/3)

Case 2 : Flood

$$M = D_0 = 1019.7 \text{ kNm/m}$$

$$V = 333.4 \text{ kN/m}$$

$$e = \frac{1019.7}{333.4} = 3.06 \text{ m}$$

Percentage of base = $3.06 / (2.3 + 0.46) = \underline{110.9\%}$ - outside of base, does not meet CDA criteria.

Case 3 : Earthquake

$$M = D_0 = 795.7 \text{ kNm/m}$$

$$e = \frac{795.7}{333.4} = 2.39 \text{ m}, \quad \text{Percentage of base} = \frac{2.39}{(2.3 + 0.46)} = \underline{86.5\%} \quad - \text{within base} \quad \checkmark \text{OK}$$

Case 4 : Post-seismic

$$M = D_0 = 1305.8 \text{ kNm/m}$$

$$e = \frac{1305.8}{333.4} = 3.92 \text{ m}, \quad \text{Percentage of base} = \frac{3.92}{(2.3 + 0.46)} = \underline{141.9\%} \quad - \text{outside base} \quad \text{doesn't meet criteria}$$

Project:

Project Number:

Date:

Page: 5

of 5

By:

Checked:

ecora

Appendix F

Check Sheets for Dam Safety Expectations, Deficiencies and Priorities

Check Sheets for Dam Safety Expectations Deficiencies and Priorities

Deficiencies and non-conformances identified during the Dam Safety Review have been evaluated in accordance with the sample check sheet for Dam Safety Expectations Deficiencies and Priorities developed by BC MoE (May 2010). Deficiencies are classified into Actual Deficiencies and Potential Deficiencies and there is a variety of non-conformances. These classifications are described as follows.

Definitions of Deficiencies and Non-Conformances

1. Deficiencies

- a. Actual – An unacceptable dam performance condition has been confirmed, based on the CDA Guidelines, or other specified safety standard. Identification of an actual deficiency generally leads to an appropriate corrective action or directly to a capital improvement project:
 - i. (An) Normal Load – Load which is expected to occur during the life of a dam.
 - ii. (Au) Unlikely Load – Load which could occur under unusual load (large earthquake or flood).
- b. Potential – There is a reason to expect that an unacceptable condition might exist, but has not been confirmed. Identification of a potential deficiency generally leads to a Deficiency Investigation:
 - i. (Pn) Normal Load – Load which is expected to occur during the life of a dam.
 - ii. (Pu) Unlikely Load – Load which could occur under unusual load (large earthquake or flood).
 - iii. (Pq) Quick – Potential deficiency that cannot be confirmed but can be readily eliminated by a specific action.
 - iv. (Pd) Difficult - Potential deficiency that is difficult or impossible to prove or disprove.

2. Non-Conformances

Established procedures, systems and instructions are not being followed, or, they are inadequate or inappropriate and should be revised:

- a. Operational (NCo), Maintenance (NCm), Surveillance (NCs).
- b. Information (NCi) – information is insufficient to confirm adequacy of dam or physical infrastructure for dam safety.
- c. Other Procedures (NCp) – other procedures, to be specified.

Table F2: Dam Safety Expectations for the Youbou Creek Dam

Dam Safety Expectations		Yes	N/A	No	Deficiencies		Non-Conformances	Comments
					Actual	Potential		
1.0 Dam Safety Analysis								
1.1	Records relevant to dam safety are available including design documents, historical instrument readings, inspection and testing reports, operational records and investigation results.			X			NCi	No engineering drawings of the dam structure were available. Limited inspection and operational records are available.
1.2	Hazards external and internal to the dam have been defined.	X						Undertaken as part of this DSR.
1.3	The potential failure modes for the dam and the initial conditions downstream from the dam have been identified.	X						Undertaken as part of this DSR.
1.4	Inundation study adequate to determine consequence classification. Flood and “sunny day” scenarios assessed.	X						Undertaken as part of this DSR.
1.5	The Dam is classified appropriately in terms of the consequences of failure including life, environmental, cultural and third-party economic losses	X						Undertaken as part of this DSR.
1.6	All other components of the water barrier (retaining walls, saddle dams, spillways, road embankments) are included in the dam safety management process.	X						
1.7	The EDGM selected reflects current seismic understanding.	X						
1.8	The IDF is based on appropriate hydrological analyses.	X						
1.9	The dam is safely capable of passing flows as required for all applicable loading conditions (normal, winter, earthquake, and flood).			X	An			Spillway is undersized and will overtop in extreme flow events.
1.10	The dam has adequate freeboard for all applicable operating conditions (normal, winter, earthquake, and flood).			X	An			Dam does not have adequate freeboard as the spillway is undersized and will overtop in extreme flow events.
1.11	The dam safety analyses (stability & hydrological) use current information and standards of practice.	X						
1.12	The approach and exit channels of discharge facilities are adequately protected against erosion and free of any obstructions that could adversely affect the discharge capacity of the facilities.			X	An			Catchment may be susceptible to development of debris flows and debris floods and thus the dam may not be adequately protected.
1.13	The dams, abutments and foundations are not subject to unacceptable deformation or overstressing.	X						
1.14	Adequate filter and drainage facilities are provided to intercept and control the maximum anticipated seepage and to prevent internal erosion.		X					Dam is constructed out of concrete and thus should not be susceptible to internal erosion.
1.15	Hydraulic gradients in the dams, abutments, foundations and along embedded structures are sufficiently low to prevent piping and instability.	X						
1.16	Slopes of an embankment have adequate protection against erosion, seepage, traffic, frost and burrowing animals		X					
1.17	Stability of reservoir slopes are evaluated under all conditions and unacceptable risk to public safety, the dam or its appurtenant structures is identified.	X						
1.18	The need for reservoir evacuation or emergency drawdown capability as a dam safety risk control measure has been assessed.	X						
2.0 Operation, Maintenance and Surveillance								
2.1	Responsibilities and authorities are clearly delegated within the organization for all dam safety activities.			X			NCo	An OMS Manual needs to be prepared for Youbou Creek Dam.
2.2	Requirements for the safe operation, maintenance and surveillance of the dam are documented with sufficient information in accordance with the impacts of operation and the consequences of dam failure.			X			NCo	An OMS Manual needs to be prepared for Youbou Creek Dam.
2.3	The OMS Manual is reviewed and updated periodically: when major changes to the structure, flow control equipment, operating conditions or company organizational structure and responsibilities have occurred.			X			NCo	An OMS Manual needs to be prepared for Youbou Creek Dam.
2.4	Documented operating procedures for the dam and flow control equipment under normal, unusual and emergency conditions exist, are consistent with the OMS Manual and are followed.			X			NCo	An OMS Manual needs to be prepared for Youbou Creek Dam.
	Operation							
2.5	Critical discharge facilities are able to operate under all expected conditions.			X	Au			Low level outlets at the base of the dam will be difficult to access if the dam is spilling or being overtopped.
a.	Flow control equipment is tested and is capable of operating as required.	X						

Dam Safety Expectations		Yes	N/A	No	Deficiencies		Non-Conformances	Comments
					Actual	Potential		
b.	Normal and standby power sources, as well as local and remote controls, are tested.		X					
c.	Testing is on a defined schedule and test results are documented and reviewed.			X			NCo	No official testing records are available.
d.	Management of debris and ice is carried out to ensure operability of discharge facilities.	X		X				
2.6	Operating procedures take into account:							
a.	Outflow from upstream dams		X					
b.	Reservoir levels and rates of drawdown			X			NCo	No procedures for drawdown rates are available.
c.	Reservoir control and discharge during an emergency			X			NCo	No emergency procedures specific to Youbou Creek Dam are available.
d.	Reliable flood forecasting information	X						
e.	Operator safety			X			NCo	No safe work procedures were available.
	Maintenance							
2.7	The particular maintenance needs of critical components or subsystems, such as flow control systems, power supply, backup power, civil structures, drainage, public safety and security measures and communications and other infrastructure are identified.			X			NCm	Assumed to be a non-conformance as no supporting documentation provided.
2.8	Maintenance procedures are documented and followed to ensure that the dam remains in a safe and operational condition.			X			NCm	Assumed to be a non-conformance as no supporting documentation provided.
2.9	Maintenance activities are prioritized and carried out with due consideration to the consequences of failure, public safety and security.			X			NCm	Assumed to be a non-conformance as no supporting documentation provided.
	Surveillance							
2.10	Documented surveillance procedures for the dam and reservoir are followed to provide early identification and to allow for timely mitigation of conditions that might affect dam safety.			X			NCm	Assumed to be a non-conformance as no supporting documentation provided.
2.11	The surveillance program provides regular monitoring of dam performance, as follows:							
a.	Actual and expected performances are compared to identify deviations.			X			NCs	Comparison of actual conditions to expected conditions documents were not available.
b.	Analysis of changes in performance, deviation from expected performance or the development of hazardous conditions.	X						
c.	Reservoir operations are confirmed to be in compliance with dam safety requirements.	X						
d.	Confirmation that adequate maintenance is being carried out.			X			NCs	Assumed to be a non-conformance as no supporting documentation provided.
2.12	The surveillance program has adequate quality assurance to maintain the integrity of data, inspection information, dam safety recommendations, training and response to unusual conditions.	X						
2.13	The frequency of inspection and monitoring activities reflects the consequences of failure, dam condition and past performance, rapidity of development of potential failure modes, access constraints due to weather or the season, regulatory requirements and security needs.	X						
2.14	Special inspections are undertaken following unusual events (if no unusual events then acknowledge that requirement to do so is documented in OMS).	X						
2.15	Training is provided so that inspectors understand the importance of their role, the value of good documentation, and the means to carry out their responsibilities effectively.			X			NCs	Assumed to be a non-conformance as no supporting documentation provided.
2.16	Qualifications and training records of all individuals with responsibilities for dam safety activities are available and maintained.			X			NCs	Assumed to be a non-conformance as no supporting documentation provided.
2.17	Procedures document how often instruments are read and by whom, where the instrument readings will be stored, how they will be processed, how they will be analyzed, what threshold values or limits are acceptable for triggering follow-up actions, what the follow-up actions should be and what instrument maintenance and calibration are necessary.			X			NCs	Assumed to be a non-conformance as no supporting documentation provided.
	3.0 Emergency Preparedness							
3.1	An emergency management process is in place for the dam including emergency response procedures and emergency preparedness plans with a level of detail that is commensurate with the consequences of failure.			X			NCo	A Dam Emergency Plan (DEP) needs to be prepared for Youbou Creek Dam

Dam Safety Expectations		Yes	N/A	No	Deficiencies		Non-Conformances	Comments
					Actual	Potential		
3.2	The emergency response procedures outline the steps that the operations staff is to follow in the event of an emergency at the dam.			X			NCp	A Dam Emergency Plan (DEP) needs to be prepared for Youbou Creek Dam.
3.3	Documentation clearly states, in order of priority, the key roles and responsibilities, as well as the required notifications and contact information.			X			NCp	A Dam Emergency Plan (DEP) needs to be prepared for Youbou Creek Dam.
3.4	The emergency response procedures cover the full range of flood management planning, normal operating procedures and surveillance procedures.			X			NCp	A Dam Emergency Plan (DEP) needs to be prepared for Youbou Creek Dam.
3.5	The emergency management process ensures that effective emergency preparedness procedures are in place for use by external response agencies with responsibilities for public safety within the floodplain.			X			NCp	A Dam Emergency Plan (DEP) needs to be prepared for Youbou Creek Dam.
3.6	Roles and responsibilities of the dam owner and response agencies are defined.			X			NCp	A Dam Emergency Plan (DEP) needs to be prepared for Youbou Creek Dam.
3.7	Inundation maps and critical flood information are appropriate and are available to downstream response agencies.			X			NCp	Inundation maps included in this report should be incorporated into a DEP and provided to the downstream response agencies.
3.8	Exercises are carried out regularly to test the emergency procedures.			X			NCp	No documentation of training exercises is available.
3.9	Staff are adequately trained in the emergency procedures.			X			NCp	No documentation of training is available.
3.10	Emergency plans are updated regularly and updated pages are distributed to all plan holders in a controlled manner.			X			NCp	A Dam Emergency Plan (DEP) needs to be prepared for Youbou Creek Dam.
4.0 Dam Safety Review								
4.1	A safety review of the dam ("Dam Safety Review") is carried out periodically based on the consequences of failure.	X						The CVRD commissioned this dam safety review. This is the first comprehensive dam safety review of this structure.
5.0 Dam Safety Management System								
5.1	The dam safety management system for the dam is in place incorporating:							
a.	Policies			X			NCo	An OMS Manual needs to be prepared for Youbou Creek Dam.
b.	Responsibilities			X			NCo	An OMS Manual needs to be prepared for Youbou Creek Dam.
c.	Plans and procedures including OMS, public safety and security			X			NCo	An OMS Manual needs to be prepared for Youbou Creek Dam.
d.	Documentation			X			NCo	Documentation of inspections prior to 2016 are missing, other documentation is limited.
e.	Training and review			X			NCo	An OMS Manual needs to be prepared for Youbou Creek Dam.
f.	Prioritization and correction of deficiencies and non-conformances	X						Prioritization of deficiencies are provided in this dam safety review.
g.	Supporting infrastructure	X						
5.2	Deficiencies are: documented, reviewed, and resolved in a timely manner. Decisions are justified and documented.			X			NCo	Prioritization of deficiencies are provided in this dam safety review.
5.3	Applicable regulations are met.			X			NCo	An OMS Manual & DEP needs to be prepared for Youbou Creek Dam.

Appendix G

NDMP Risk Assessment Information Template



National Disaster Mitigation Program (NDMP) Risk Assessment Information Template

Risk Event Details		Start Date:	End Date:
Start and End Date	Provide the start and end dates of the selected event, based on historical data.	05/11/2018	Ongoing
Severity of the Risk Event	Provide details about the risk, including: <ul style="list-style-type: none"> • Speed of onset and duration of event; • Level and type of damaged caused; • Insurable and non-insurable losses; and • Other details, as appropriate. 	<p>A comprehensive Dam Safety Review and Risk Assessment was undertaken of the Youbou Creek Dam in 2018 to meet the CVRD obligation as a water licensee under the BC Dam Safety Regulations. The dam safety review includes a dam breach analysis, flood routing, inundation mapping and assessment of the performance of the dam structure to resist failure under normal and extreme loads. This includes assessment of various meteorological and seismic hazards.</p> <p>Flood routing inundation mapping indicates that hazardous flow conditions downstream of the dam would occur within an hour of the initiation of the dam breach.</p> <p>The results of the dam safety review and risk assessment indicated the following infrastructure is at risk in the event of a dam breach:</p> <ol style="list-style-type: none"> 1. Youbou Road 2. Arbutus Park 3. Youbou Fire Department 4. Other Minor Roads 	
Response During the Risk Event	Provide details on how the defined geographic area continued its essential operations while responding to the event.	N/A	
Recovery Method for the Risk Event	Provide details on how the defined geographic area recovered.	Recovery is anticipated to include the investigation, design and construction of a replacement dam structure that would meet the performance criteria contain within the BC Dam Safety Regulations, Canadian Dam Association Dam Safety Guidelines and Associated Technical Bulletins.	

<p>Recovery Costs Related to the Risk Event</p>	<p>Provide details on the costs, in dollars, associated with implementing recovery strategies following the event.</p>	<p>Dam reconstruction and restoration of roads: \$1,000,000 Potential additional costs</p>
<p>Recovery Time Related to the Risk Event</p>	<p>Provide details on the recovery time needed to return to normal operations following the event.</p>	<p>Unknown</p>



National Disaster Mitigation Program Risk Assessment Information Template

UNCLASSIFIED

<p>Risk Event Identification and Overview</p> <p>Provide a qualitative description of the defined geographic area, including:</p> <ul style="list-style-type: none"> • Watershed/community/region name(s); • Province/Territory; • Area type (i.e., city, township, watershed, organization, etc.); • Population size; • Population variances (e.g., significant change in population between summer and winter months); • Main economic areas of interest; • Special consideration areas (e.g., historical, cultural and natural resource areas); and an • Estimate of the annual operating budget of the area. 	<p>Watershed is the Youbou Creek Watershed Youbou, British Columbia Vancouver Island Region Area type: Youbou Creek watershed Population Size: 1,086 Population Variance: Unknown Main Economic Interests: Forestry, Tourism Special Considerations: Arbutus Park Estimate of Annual Operating Budget: Unknown</p>
<p>Methodologies, processes and analyses</p> <p>Provide the year in which the following processes/analyses were last completed and state the methodology(ies) used:</p> <ul style="list-style-type: none"> • Hazard identification; • Vulnerability analysis; • Likelihood assessment; • Impact assessment; • Risk assessment; • Resiliency assessment; and/or • Climate change impact and/or adaptation assessment. <p><i>Note: It is recognized that many of the processes/analyses mentioned above may be included within one methodology.</i></p>	<p>Analysis completed during the 2018 Comprehensive Dam Safety Review and Risk Assessment of the Youbou Creek Dam, prepared by Ecora Engineering & Resource Group Ltd.</p> <p>Report includes: Dam embankment stability analysis, dam breach assessment, dam hydrotechnical assessment including wind-wave analysis.</p> <p>Hazards, vulnerability, likelihood, impact, risk are assigned as a result of analysis.</p>



National Disaster Mitigation Program Risk Assessment Information Template

UNCLASSIFIED

Hazard Mapping	
<p>To complete this section:</p> <ul style="list-style-type: none"> Obtain a map of the area that clearly indicates general land uses, neighbourhoods, landmarks, etc. For clarity throughout this exercise, it may be beneficial to omit any non-essential information from the map intended for use. Controlled photographs (e.g. aerial photography) can be used in place of or in addition to existing maps to avoid the cost of producing new maps. Place a grid over the maps/photographs of the area and assign row and column identifiers. This will help identify the specific area(s) that may be impacted, as well as additional information on the characteristics within and affecting the area. Identify where and how flood hazards may affect the defined geographic area. Identify the mapped areas that are most likely to be impacted by the identified flood hazard. <p>Map(s)/photograph(s) can also be used, where appropriate, to visually represent the information/prioritization being provided as part of this template.</p>	
Hazard identification and prioritization	
List known or likely flood hazards to the defined geographic area in order of proposed priority. For example: (1) dyke breach overland flooding; (2) urban storm surge flooding ; and so on.	1. Dam breach of Youbou Creek Dam and overland flooding
Provide a rationale for each prioritization and the key information sources supporting this rationale.	1. The 2018 Comprehensive Dam Safety Review and Risk Assessment of the Youbou Creek Dam indicated that the dam in its current form does not meet the performance criteria contained within the BC Dam Safety Regulations, Canadian Dam Association Dam Safety Guidelines and Associated Technical Bulletins and is at risk of structural failure due to internal erosion or a seismic event. 2018 Comprehensive Dam Safety Review and Risk Assessment of the Youbou Creek Dam, prepared by Ecora Engineering & Resource Group Ltd.
Risk Event Title	
Identify the name/title of the risk. An example of a risk event name or title is: "A one-in-one hundred year flood following an extreme rain event."	Dam breach and overland flooding due to a one-in-one hundred year flood.
Type of Flood Hazard	



National Disaster Mitigation Program Risk Assessment Information Template

UNCLASSIFIED

<p>Identify the type of flood hazard being described (e.g., riverine flooding, coastal inundation, urban run-off, etc.)</p>	<p>Riverine flooding and associated bank erosion. Failure and over topping of hydraulic structures.</p>
<p>Secondary hazards</p>	
<p>Describe any secondary effects resulting from the risk event (e.g., flooding that occurs following a hurricane).</p>	<p>Erosion and bank instabilities downstream of the dam failure due to elevated flows. Failure of road embankments where hydraulic structures are overwhelmed by breach flows.</p>
<p>Primary and secondary organizations for response</p>	
<p>Identify the primary organization(s) with a mandate related to a key element of a natural disaster emergency, and any supporting organization(s) that provide general or specialized assistance in response to a natural disaster emergency.</p>	<p>The Cowichan Valley Regional District and the BC Ministry of Transportation & Infrastructure and Emergency Management BC would be the primary organizations with a mandate to respond to a natural disaster emergency at the subject site.</p>
<p>Risk Event Description</p>	
<p>Description of risk event, including risk statement and cause(s) of the event</p>	
<p>Provide a baseline description of the risk event, including:</p> <ul style="list-style-type: none"> • Risk statement; • Context of the risk event; • Nature and scale of the risk event; • Lead-up to the risk event, including underlying cause and trigger/stimulus of the risk event; and • Any factors that could affect future events. <p><i>Note: The description entered here must be plausible in that factual information would support such a risk event.</i></p>	<p>The primary risk event is the breach of Youbou Creek Dam. This can be caused by a flood event, an earthquake or further deterioration of the concrete structure.</p> <p>In the event of dam breach significant damage to public infrastructure would occur including damage to Youbou Road, Arbutus Park and Youbou Fire Department.</p> <p>The event would most likely occur in the spring freshet period when the lake levels and hydrostatic pressures within the dam are higher.</p>



National Disaster Mitigation Program Risk Assessment Information Template

UNCLASSIFIED

<p>Location</p> <p>Provide details regarding the area impacted by the risk event such as:</p> <ul style="list-style-type: none"> • Province(s)/territory(ies); • Region(s) or watershed(s); • Municipality(ies); • Community(ies); and so on. 	<p>Youbou Creek is located on the north shore of Cowichan Lake on Vancouver Island on the coast of British Columbia. The Creek passes through the western part of the community of Youbou between Arbutus Park and the Youbou Fire Department.</p> <p>A dam breach has the potential to disrupt transportation traveling between west and east sides of Cowichan Lake.</p>
<p>Natural environment considerations</p> <p>Document relevant physical or environmental characteristics of the defined geographic area.</p>	<p>The Youbou Creek watershed is heavily forested around the creek, logging has taken place in areas close proximity. Elevation of the catchment varies from 164 m near Cowichan Lake to 1110 m at the top of the catchment.</p>
<p>Meteorological conditions</p> <p>Identify the relevant meteorological conditions that may influence the outcome of the risk event.</p>	<p>Relevant meteorological conditions may include:</p> <ul style="list-style-type: none"> - High snowpack in the Youbou Creek watershed - High temperature as snow thaws - Extreme rainfall - Extreme rain on snow



National Disaster Mitigation Program Risk Assessment Information Template

UNCLASSIFIED

<p>Seasonal conditions</p> <p>Identify the relevant seasonal changes that may influence the outcome of the risk assessment of a particular risk event.</p>	<p>Relevant seasonal conditions may include:</p> <ul style="list-style-type: none"> - Extreme precipitation - Wood debris in the dam spillway - Changing watershed conditions due wildfire, logging and other factors
<p>Nature and vulnerability</p>	
<p>Document key elements related to the affected population, including:</p> <ul style="list-style-type: none"> • Population density; • Vulnerable populations (identify these on the hazard map from step 7); • Degree of urbanization; • Key local infrastructure in the defined geographic area; • Economic and political considerations; and • Other elements, as deemed pertinent to the defined geographic area. 	<p>Population density for Youbou: 122.8 people per square km.</p> <p>Hazardous area is identified on hazards maps included with the 2018 Comprehensive Dam Safety Review and Risk Assessment completed by Ecora.</p> <p>Area around creek is mostly rural with development only existing in the lower ranges of the catchment.</p> <p>Key local infrastructure:</p> <ol style="list-style-type: none"> 1. Youbou Road 2. Arbutus Park 3. Youbou Fire Department 4. Other Minor Roads <p>Economic and political considerations: A dam breach will impact local roads and parks.</p>



National Disaster Mitigation Program Risk Assessment Information Template

UNCLASSIFIED

<p>Asset inventory</p> <p>Identify the asset inventory of the defined geographic area, including:</p> <ul style="list-style-type: none"> • Critical assets; • Cultural or historical assets; • Commercial assets; and • Other area assets, as applicable to the defined geographic area. <p>Key asset-related information should also be provided, including:</p> <ul style="list-style-type: none"> • Location on the hazard map (from step 7); • Size; • Structure replacement cost; • Content value; • Displacement costs; • Importance rating and rationale; • Vulnerability rating and reason; and • Average daily cost to operate. <p>A total estimated value of physical assets in the area should also be provided.</p>	<p>Key local assets that are within the flow area include:</p> <ol style="list-style-type: none"> 1. Youbou Road 2. Downstream creek crossing below Youbou Creek Dam <p>Possible further damage from overland flooding through Youbou. No detailed cost estimate has taken place, however total impact cost is estimated to be below or around \$3 million dollars.</p>
<p>Other assumptions, variability and/or relevant information</p> <p>Identify any assumptions made in describing the risk event; define details regarding any areas of uncertainty or unpredictability around the risk event; and supply any supplemental information, as applicable.</p>	<p>A breach of the dam could be the result of a number of scenarios and thus it is difficult to say which scenario would be the first that causes dam failure. As per Canadian Dam Association (CDA) guidelines the most conservative scenario was considered. Dam breach analysis assumed a sudden failure of the dam during a 100-year inflow event. Some variation between the modeled breach and a real breach may exist due to variation in terrain that may not entirely captured in the digital terrain model used.</p>
<p>Existing Risk Treatment Measures</p>	
<p>Identify existing risk treatment measures that are currently in place within the defined geographic area to mitigate the risk event, and describe the sufficiency of these risk treatment measures.</p>	<p>It is anticipated that downstream culverts along Youbou Creek would be at most sized for a 200-year flood event. The inflow from a failure during an extreme event will likely be greater than the actual capacity of the culverts.</p>



National Disaster Mitigation Program Risk Assessment Information Template

UNCLASSIFIED

Likelihood Assessment	
Return Period	1 in 100-year
Identify the time period during which the risk event might occur. For example, the risk event described is expected to occur once every X number of years. Applicants are asked to provide the X value for the risk event.	
Period of interest	
Applicants are asked to determine and identify the likelihood rating (i.e. period of interest) for the risk event described by using the likelihood rating scale within the table below.	
Likelihood Rating	Definition
5	The event is expected and may be triggered by conditions expected over a 30 year period.
4	The event is expected and may be triggered by conditions expected over a 30 - 50 year period.
3	The event is expected and may be triggered by conditions expected over a 50 - 500 year period.
2	The event is expected and may be triggered by conditions expected over a 500 - 5000 year period.
1	The event is possible and may be triggered by conditions exceeding a period of 5000 years.
Provide any other relevant information, notes or comments relating to the likelihood assessment, as applicable.	
Dam does not meet current CDA requirements in terms of sliding failure under static, flood, earthquake or post earthquake and does not meet CDA requirements for overturning under a post-earthquake condition. For the purpose of this study a 1 in 100-year event has been considered. The 1 in 100-year condition was considered as the inflow design flood for the dam corresponds to this event but it is noted that the failure may occur at a lower return period flood.	



National Disaster Mitigation Program Risk Assessment Information Template

UNCLASSIFIED

Impacts/Consequences Assessment		
<p>There are 12 impacts categories within 5 impact classes rated on a scale of 1 (least impacts) to 5 (greatest impact). Conduct an assessment of the impacts associated with the risk event, and assign one risk rating for each category. Additional information may be provided for each of the categories in the supplemental fields provided.</p>		
A) People and societal impacts		
Risk Rating	Definition	Assigned risk rating
5	Could result in more than 50 fatalities	
4	Could result in 10 - 49 fatalities	
3	Could result in 5 - 9 fatalities	2
2	Could result in 1 - 4 fatalities	
1	Not likely to result in fatalities	
Supplemental information (optional)	No permanent population at risk (PAR) was identified within the dam inundation zone, however transient population such as road users would be in the inundation zone that could result in fatalities.	
Injuries	5	Injuries, illness and/or psychological disablements cannot be addressed by local, regional, or provincial/territorial healthcare resources; federal support or intervention is required
	4	Injuries, illnesses and/or psychological disablements cannot be addressed by local or regional healthcare resources; provincial/territorial healthcare support or intervention is required.
	3	Injuries, illnesses and/or psychological disablements cannot be addressed by local or regional healthcare resources additional healthcare support or intervention is required from other regions, and supplementary support could be required from the province/territory
	2	Injuries, illnesses and/or psychological disablements cannot be addressed by local resources through local facilities; healthcare support is required from other areas such as an adjacent area(ies)/municipality(ies) within the region
	1	Any injuries, illnesses, and/or psychological disablements can be addressed by local resources through local facilities; available resources can meet the demand for care
Supplemental information (optional)	Closest hospital to impacted area is the Cowichan District Hospital approximately 40 km away.	



National Disaster Mitigation Program Risk Assessment Information Template

UNCLASSIFIED

		Risk Rating	Definition	Assigned risk rating
Displacement	Percentage of displaced individuals	5	> 15% of total local population	1
		4	10 - 14.9% of total local population	
		3	5 - 9.9% of total local population	
		2	2 - 4.9% of total local population	
		1	0 - 1.9% of total local population	
Displacement	Duration of displacement	5	> 26 weeks (6 months)	4
		4	4 weeks - 26 weeks (6 months)	
		3	1 week - 4 weeks	
		2	72 hours - 168 hours (1 week)	
		1	Less than 72 hours	
Supplemental information (optional)		Primary impact will be to a temporary population. The duration of displacement could be a number of weeks as road access is restored. Will also take some time for drinking water systems to be restored.		
B) Environmental impacts				
		5	> 75% of flora or fauna impacted or 1 or more ecosystems significantly impaired; Air quality has significantly deteriorated; Water quality is significantly lower than normal or water level is > 3 meters above highest natural level; Soil quality or quantity is significantly lower (i.e., significant soil loss, evidence of lethal soil contamination) than normal; > 15% of local area is affected	2
		4	40 - 74.9% of flora or fauna impacted or 1 or more ecosystems considerably impaired; Air quality has considerably deteriorated; Water quality is considerably lower than normal or water level is 2 - 2.9 meters above highest natural level; Soil quality or quantity is moderately lower than normal; 10 - 14.9% of local area is affected	
		3	10 - 39.9% of flora or fauna impacted or 1 or more ecosystems moderately impaired; Air quality has moderately deteriorated; Water quality is moderately lower than normal or water level is 1 - 2 meters above highest natural level; Soil quality is moderately lower than normal; 6 - 9.9 % of area affected	



**National Disaster Mitigation Program
Risk Assessment Information Template**

UNCLASSIFIED

	2	<p>< 10 % of flora or fauna impacted or little or no impact to any ecosystems; Little to no impact to air quality and/or soil quality or quantity; Water quality is slightly lower than normal, or water level is less than 0.9 meters above highest natural level and increased for less than 24 hours; 3 - 5.9 % of local area is affected</p>	
	1	<p>Little to no impact to flora or fauna, any ecosystems, air quality, water quality or quantity, or to soil quality or quantity; 0 - 2.9 % of local area is affected</p>	
Supplemental information (optional)	Elevated water levels are expected for a period of less than 24 hours as the flood wave moves downstream.		
C) Local economic impacts			
	Risk Rating	Definition	Assigned risk rating
	5	> 15 % of local economy impacted	
	4	10 - 14.9 % of local economy impacted	
	3	6 - 9.9 % of local economy impacted	5
	2	3 - 5.9 % of local economy impacted	
	1	0 - 2.9 % of local economy impacted	
Supplemental information (optional)	Access to the west along Youbou Road will be restricted.		



**National Disaster Mitigation Program
Risk Assessment Information Template**

UNCLASSIFIED

D) Local infrastructure impacts		Risk Rating	Definition	Assigned risk rating
Transportation	5	Local activity stopped for more than 72 hours; > 20% of local population affected; lost access to local area and/or delivery of crucial service or product; or having an international level impact	1	
	4	Local activity stopped for 48 - 71 hours; 10 - 19.9% of local population affected; significantly reduced access to local area and/or delivery of crucial service or product; or having a national level impact		
	3	Local activity stopped for 25 - 47 hours; 5 - 9.9% of local population affected; moderately reduced access to local area and/or delivery of crucial service or product; or having a provincial/territorial level impact		
	2	Local activity stopped for 13 - 24 hours; 2 - 4.9% of local population affected; minor reduction in access to local area and/or delivery of crucial service or product; or having a regional level impact		
	1	Local activity stopped for 0 - 12 hours; 0 - 1.9% of local population affected; little to no reduction in access to local area and/or delivery of crucial service or product		
Supplemental information (optional)				
Energy and Utilities	5	Duration of impacts > 72 hours; > 20% of local population without service or product; or having an international level impact	5	
	4	Duration of impact 48 - 71 hours; 10 - 19.9% of local population without service or product; or having a national impact		
	3	Duration of impact 25 - 47 hours; 5 - 9.9% of local population without service or product; or having a provincial/territorial level impact		
	2	Duration of impact 13 - 24 hours; 2 - 4.9% of local population without service or product; or having a regional level impact		
	1	Local activity stopped for 0 - 12 hours; 0 - 1.9% of local population affected; little to no reduction in access to local area and/or delivery of crucial service or product		



**National Disaster Mitigation Program
Risk Assessment Information Template**

UNCLASSIFIED

Supplemental information (optional)	5	Service unavailable for > 72 hours; > 20 % of local population without service; or having an international level impact	1
	4	Service unavailable for 48 - 71 hours; 10 - 19.9 % of local population without service; or having a national level impact	
	3	Service unavailable for 25 - 47 hours; 5 - 9.9 % of local population without service; or having a provincial/territorial level impact	
	2	Service unavailable for 13 - 24 hours; 2 - 4.9 % of local population without service; or having a regional level impact	
	1	Service unavailable for 0 - 12 hours; 0 - 1.9 % of local population without service	
Supplemental information (optional)			
Health, Food, and Water	5	Inability to access potable water, food, sanitation services, or healthcare services for > 72 hours; non - essential services cancelled; > 20 % of local population impacted; or having an international level impact	5
	4	Inability to access potable water, food, sanitation services, or healthcare services for 48 - 72 hours; major delays for nonessential services; 10 - 19.9 % of local population impacted; or having a national level impact	
	3	Inability to access potable water, food, sanitation services, or healthcare services for 25 - 48 hours; moderate delays for nonessential services; 5 - 9.9 % of local population impacted; or having a provincial/territorial level impact	
	2	Inability to access potable water, food, sanitation services, or healthcare services for 13 - 24 hours; minor delays for nonessential; 2 - 4.9 % of local population impacted; or having a regional level impact	
	1	Inability to access potable water, food, sanitation services, or healthcare services for 0 - 12 hours; 0 - 1.9 % of local population impacted	



National Disaster Mitigation Program
Risk Assessment Information Template

UNCLASSIFIED

Supplemental information (optional)	5	> 20 % of local population impacted; loss of intelligence or defence assets or systems for > 72 hours; or having an international level impact	
	4	10 - 19.9 % of local population impacted; loss of intelligence or defence assets or systems for 48 - 71 hours; or having a national level impact	
	3	5 - 9.9 % of local population impacted; loss of intelligence or defence assets or systems for 25 - 47 hours; or having a provincial/territorial level impact	
	2	2 - 4.9 % of local population impacted; loss of intelligence or defence assets or systems for 13 - 24 hours; or having a regional level impact	
	1	0 - 1.9 % of local population impacted; loss of intelligence or defence assets or systems for 0 - 12 hours	
Safety and Security		2	
Supplemental information (optional)			



**National Disaster Mitigation Program
Risk Assessment Information Template**

UNCLASSIFIED

E) Public sensitivity impacts		Risk Rating	Definition	Assigned risk rating
	5	Sustained, long term loss in reputation/public perception of public institutions and/or sustained, long term loss of trust and confidence in public institutions; or having an international level impact	2	
	4	Significant loss in reputation/public perception of public institutions and/or significant loss of trust and confidence in public institutions; significant resistance; or having a national level impact		
	3	Some loss in reputation/public perception of public institutions and/or some loss of trust and confidence in public institutions; escalating resistance		
	2	Isolated/minor, recoverable set - back in reputation, public perception, trust, and/or confidence of public institutions		
	1	No impact on reputation, public perception, trust, and/or confidence of public institutions		
Supplemental information (optional)				



**National Disaster Mitigation Program
Risk Assessment Information Template**

UNCLASSIFIED

Confidence Assessment

Based on the table below, indicate the level of confidence regarding the information entered in the risk assessment information template in the "Confidence Level Assigned" column. Confidence levels are language - based and range from A to E (A=most confident to E=least confident).

Confidence Level	Definition	Confidence Level Assigned
A	<p>Very high degree of confidence Risk assessment used to inform the risk assessment information template was evidence - based on a thorough knowledge of the natural hazard risk event; leveraged a significant quantity of high - quality data that was quantitative and qualitative in nature; leveraged a wide variety of data and information including from historical records, geospatial and other information sources; and the risk assessment and analysis processes were completed by a multidisciplinary team with subject matter experts (i.e., a wide array of experts and knowledgeable individuals on the specific natural hazard and its consequences) Assessment of impacts considered a significant number of existing/known mitigation measures</p>	
B	<p>High degree of confidence Risk assessment used to inform the risk assessment information template was evidence - based on a thorough knowledge of the natural hazard risk event; leveraged a significant quantity of data that was quantitative and qualitative in nature; leveraged a wide variety of data and information including from historical records, geospatial and other information sources; and the risk assessment and analysis processes were completed by a multidisciplinary team with some subject matter expertise (i.e., a wide array of experts and knowledgeable individuals on the specific natural hazard and its consequences) Assessment of impacts considered a significant number of potential mitigation measures</p>	



National Disaster Mitigation Program Risk Assessment Information Template

UNCLASSIFIED

<p>C</p>	<p>Moderate confidence Risk assessment used to inform the risk assessment information template was moderately evidence - based from a considerable amount of knowledge of the natural hazard risk event; leveraged a considerable quantity of data that was quantitative and/or qualitative in nature; leveraged a considerable amount of data and information including from historical records, geospatial and other information sources; and the risk assessment and analysis processes were completed by a moderately sized multidisciplinary team, incorporating some subject matter experts (i.e., a wide array of experts and knowledgeable individuals on the specific natural hazard and its consequences) Assessment of impacts considered a large number of potential mitigation measures</p>	<p>C</p>
<p>D</p>	<p>Low confidence Risk assessment used to inform the risk assessment information template was based on a relatively small amount of knowledge of the natural hazard risk event; leveraged a relatively small quantity of quantitative and/or qualitative data that was largely historical in nature; may have leveraged some geospatial information or information from other sources (i.e., databases, key risk and resilience methodologies); and the risk assessment and analysis processes were completed by a small team that may or may not have incorporated subject matter experts (i.e., did not include a wide array of experts and knowledgeable individuals on the specific natural hazard and its consequences). Assessment of impacts considered a relatively small number of potential mitigation measures</p>	
<p>E</p>	<p>Very low confidence Risk assessment used to inform the risk assessment information template was not evidence - based; leveraged a small quantity of information and/or data relating to the natural risk hazard and risk event; primary qualitative information used with little to no quantitative data or information; and the risk assessment and analysis processes were completed by an individual or small group of individuals little subject matter expertise (i.e., did not include a wide array of experts and knowledgeable individuals on the specific natural hazard and its consequences). Assessment of impacts did not consider existing or potential mitigation measures</p>	
<p>Rationale for level of confidence</p>		
<p>Provide the rationale for the selected confidence level, including any references or sources to support the level assigned.</p>	<p>The risk assessment considered multiple risk events including the probabilistic (5th Generation) seismic hazard model developed by the Geological Survey of Canada (GSC) (Halchuk, Adams and Allen, 2015) that forms the basis of the seismic design provisions of the 2015 National Building Code of Canada (NBCC, 2015). Only one mitigation measure was considered as rehabilitation of the existing dam structure is the most logical option.</p>	



National Disaster Mitigation Program Risk Assessment Information Template

UNCLASSIFIED

Key Information Sources	
<p>Identify all supporting documentation and information sources for qualitative and quantitative data used to identify risk events, develop the risk event description, and assess impacts and likelihood. This ensures credibility and validity of risk information presented as well as enables referencing back to decision points at any point in time.</p> <p>Clearly identify unclassified and classified information.</p>	<p>Comprehensive Dam Safety Review and Risk Assessment of Youbou Creek Dam, prepared by Ecora Engineering & Resource Group Ltd. in draft from 2018.</p> <p>Unclassified.</p>
Description of the risk analysis team	
<p>List and describe the type and level of experience of each individual who was involved with the completion of the risk assessment and risk analysis used to inform the information contained within this risk assessment information template.</p>	<p>Michael J. Laws, P.Eng. Senior Geotechnical & Dam Safety Engineer Dr. Adrian Chantler, P.Eng. Senior Hydrotechnical Engineer</p>

Appendix H

Dam Safety Assurance Statement

APPENDIX C1: DAM SAFETY REVIEW ASSURANCE STATEMENT – WATER RESERVOIR DAMS

Note: This statement is to be read and completed in conjunction with the current APEGBC *Professional Practice Guidelines – Legislated Dam Safety Reviews in British Columbia*, (“APEGBC Guidelines”) and is to be provided for dam safety review reports for the purposes of the *Dam Safety Regulation*, BC Reg. 40/2016 as amended. Italicized words are defined in the APEGBC Guidelines.

To: The Owner(s)

Date: March 19, 2019

Cowichan Valley Regional District

Name 175 Ingram Street

Duncan, BC V9L 1N8

Address

With reference to the *Dam Safety Regulation*, B.C. Reg. 40/2016 as amended.

For the dam:

UTM (Location): E410956, N5414653 (Zone 10)

Located at (Description): Near Community Lane, Youbou, BC

Name of dam or description: Youbou Creek Dam

Provincial dam number: D730170-00

Dam function: Township water supply for Youbou

Owned by: Cowichan Valley Regional District

(the “Dam”)

Current Dam classification is:

Check one

- Low
- Significant
- High
- Very High
- Extreme

The undersigned hereby gives assurance that he/she is a Qualified Professional Engineer.

I have signed, sealed and dated the attached dam safety review report on the Dam in accordance with the APEGBC Guidelines. That report must be read in conjunction with this Statement. In preparing that report I have:

Check to the left of applicable items (see Guideline Section 3.2):

- 1. Collected and reviewed available and relevant background information, documentation and data
- 2. Understood the current classification for the Dam, including performance expectations
- 3. Undertaken an initial facility review
- 4. Reviewed and assessed the Dam safety management obligations and procedures
- 5. Reviewed the condition of the Dam, reservoir and relevant upstream and downstream portions of the river
- 6. Interviewed operations and maintenance personnel
- 7. Reviewed available maintenance records, the Operations, Maintenance and Surveillance (OMS) Manual and the Dam Emergency Plan
- 8. Confirmed proper functioning of flow control equipment
- 9. After the above, reassess the consequence classification, including the identification of required dam safety criteria
- 10. Carried out a dam safety analysis based on the classification in 9. above
- 11. Evaluated facility performance
- 12. Identified, characterized and determined the severity of deficiencies in the safe operation of the Dam and non-conformances in dam safety management system
- 13. Recommended and prioritized actions to be taken in relation to deficiencies and non-conformances
- 14. Prepared a dam safety review report for submittal to the regulatory authority by the Owner and reviewed the report with the Owner
- 15. The dam safety review report has been reviewed in meeting the intent of APEGBC Bylaw 14(b)(2)

Based on my dam safety review, the current dam classification is:

Check one

- Appropriate
- Should be reviewed and amended

I undertook the following type of dam safety review:

Check one

- Audit
- Comprehensive
- Detailed design-based multi-disciplinary
- Comprehensive, detailed design and performance

I hereby give my assurance that, based on the attached dam safety review report, at this point in time:

Check one

- The Dam is reasonably safe in that the dam safety review did not reveal any unsafe or unacceptable conditions in relation to the design, construction, maintenance and operation of the Dam as set out in the attached dam safety review report
- The Dam is reasonably safe but the dam safety review did reveal non-conformances with the *Dam Safety Regulation* as set out in section(s) ____ of the attached dam safety review report.
- The Dam is reasonably safe but the dam safety review did reveal deficiencies and non-conformances as set out in section(s) ____ of the attached dam safety review report.
- The Dam is not safe in that the dam safety review did reveal deficiencies and/or non-conformances which require urgent action as set out in section(s) ____ of the attached dam safety review report.
10.5, 12 & 13

Michael J. Laws, P.Eng.

Name

March 19, 2019

Date

Signature

579 Lawrence Avenue, Kelowna, BC V1Y 6L8

Address

250.469.9757

Telephone

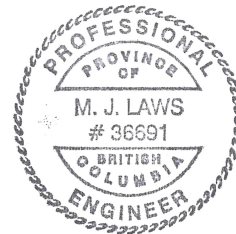

(Affix Professional Seal here)

If the Qualified Professional Engineer is a member of a firm, complete the following:

I am a member of the firm Ecora Engineering & Resource Group Ltd.

and I sign this letter on behalf of the firm.

(Print name of firm)

Appendix I

Statement of General Conditions – Geotechnical

Standard of Care

Ecora Engineering and Resource Group Ltd. (Ecora) has prepared this report in a manner consistent with that level of care and skill ordinarily exercised by members of the engineering and science professions currently practicing under similar conditions in the jurisdiction in which the services are provided, subject to the time limits and physical constraints applicable to this report. No other warranty, expressed or implied is made.

Basis and Use of the Report

This report and the recommendations contained in it are intended for the sole use of Ecora's Client. Ecora does not accept any responsibility for the accuracy of any of the data, the analyses or the recommendations contained or referenced in the report when the report is used or relied upon by any party other than Ecora's Client unless otherwise authorized in writing by Ecora. Any unauthorized use of the report is at the sole risk of the user. In order to properly understand the suggestions, recommendations and opinions expressed herein, reference must be made to the whole of the report. We cannot be responsible for use by any party of portions of the report without reference to the whole report.

This report is subject to copyright and shall not be reproduced either wholly or in part without the prior, written permission of Ecora. Additional copies of the report, if required, may be obtained upon request.

Alternate Report Format

Where Ecora submits both electronic file and hard copy versions of reports, drawings and other project-related documents, only the signed and/or sealed versions shall be considered final and legally binding. The original signed and/or sealed version archived by Ecora shall be deemed to be the original for the Project. Both electronic file and hard copy versions of Ecora's deliverables shall not, under any circumstances, no matter who owns or uses them, be altered by any party except Ecora.

Soil, Rock and Groundwater Conditions

Classification and identification of soils, rocks and geological units have been based upon commonly accepted systems and methods employed in professional geotechnical practice. This report contains descriptions of the systems and methods used. Classification and identification of the type and condition of these materials or units involves judgment, and boundaries between different soil, rock or geologic types or units may be transitional rather than abrupt. Accordingly, Ecora does not warrant conditions represented herein as exact, but infers accuracy only to the extent that is common in practice.

Soil and groundwater conditions shown in the factual data and described in the report are the observed conditions at the time of their determination or measurement. Unless otherwise noted, those conditions form the basis of the recommendations in the report. Groundwater conditions may vary between and beyond reported locations and can be affected by annual, seasonal and meteorological conditions. The condition of the soil, rock and groundwater may be significantly altered by construction activities such as traffic, excavation, groundwater level lowering, pile driving, blasting on the site or on adjacent sites. Excavation may expose the soils to climatic elements such as freeze/thaw and wet /dry cycles and/or mechanical disturbance which can cause severe deterioration. Unless otherwise indicated the soil must be protected from these changes during construction.

Environmental and Regulatory Issues

The professional services retained for this project include only the geotechnical aspects of the subsurface conditions at the site, unless otherwise specifically stated and identified in the report. The presence or implication(s) of possible surface and/or subsurface contamination resulting from previous activities or uses of the site and/or resulting from the introduction onto the site of materials from off-site sources are outside the terms of reference for this project and have not been investigated or addressed.

Sample Disposal

Ecora will dispose all soil and rock samples for 30 days following issue of this report. Further storage or transfer of samples can be made at the Client's expense upon written request, otherwise samples will be discarded.

Construction Services

During construction, Ecora should be retained to perform sufficient and timely observations of encountered conditions to confirm and document that the subsurface conditions do not materially differ from those interpreted conditions considered in the preparation of Ecora's report and to confirm and document that construction activities do not adversely affect the suggestions, recommendations and opinions contained in Ecora's report. Adequate field review, observation and testing during construction are necessary for Ecora to be able to provide letters of assurance, in accordance with the requirements of many regulatory authorities. In cases where this recommendation is not followed, Ecora's responsibility is limited to interpreting accurately the information encountered at the borehole locations, at the time of their initial determination or measurement during the preparation of the Report.

Job Site Safety

Ecora is responsible only for the activities of our employees on the jobsite. The presence of Ecora's personnel on the site shall not be construed in any way to relieve the Client or any contractors on site from their responsibilities for site safety. The Client acknowledges that he, his representatives, contractors or others retain control of the site and that Ecora never occupy a position of control of the site. The Client undertakes to inform Ecora of all hazardous conditions, or other relevant conditions of which the Client is aware. The Client also recognizes that our activities may uncover previously unknown hazardous conditions or materials and that such a discovery may result in the necessity to undertake emergency procedures to protect our employees as well as the public at large and the environment in general.

Changed Conditions and Drainage

Where conditions encountered at the site differ significantly from those anticipated in this report, either due to natural variability of subsurface conditions or construction activities, it is a condition of this report that Ecora be notified of any changes and be provided with an opportunity to review or revise the recommendations within this report. Recognition of changed soil and rock conditions requires experience and it is recommended that Ecora be employed to visit the site with sufficient frequency to detect if conditions have changed significantly. Drainage of subsurface water is commonly required either for temporary or permanent installations for the project. Improper design or construction of drainage or dewatering can have serious consequences. Ecora takes no responsibility for the effects of drainage unless specifically involved in the detailed design and construction monitoring of the system.

Services of Sub consultants and Contractors

The conduct of engineering and environmental studies frequently requires hiring the services of individuals and companies with special expertise and/or services which we do not provide. Ecora may arrange the hiring of these services as a convenience to our Clients. As these services are for the Client's benefit, the Client agrees to hold the Company harmless and to indemnify and defend Ecora from and against all claims arising through such hiring's to the extent that the Client would incur had he hired those services directly. This includes responsibility for payment for services rendered and pursuit of damages for errors, omissions or negligence by those parties in carrying out their work. In particular, these conditions apply to the use of drilling, excavation and laboratory testing services.